

Low voltage circuit breakers

Working with trip characteristic curves

| | |
|---|----|
| 1. Introduction | 2 |
| 2. Main Definitions | 3 |
| 3. ABB Low Voltage Circuit Breakers complying with the Standards UL 489 and UL 1066 | |
| 3.1 Common terms– on Low Voltage Circuit Breakers | 7 |
| 3.2 ABB Low Voltage Circuit Breakers | 8 |
| 3.2.1 Molded-Case Circuit Breakers (Tmax)..... | 8 |
| 3.2.2 Low Voltage Power Circuit Breakers (Emax)..... | 10 |
| 4. Thermal Magnetic and Electronic Trip Units for ABB Circuit Breakers | |
| 4.1 Thermal Magnetic Trip Units | 12 |
| 4.1.1 Overload Protection (L) | 12 |
| 4.1.2 Instantaneous Short Circuit Protection (I) | 12 |
| 4.1.3 Thermal magnetic Trip Units for Tmax Circuit Breakers | 13 |
| 4.1.3.1 Time-Current Curve of a Thermal magnetic Trip Unit TMA | 14 |
| 4.1.3.2 Setting Examples of a Trip Unit TMA..... | 15 |
| 4.2 Electronic Trip Units | 16 |
| 4.2.1 Overload Protection (L) | 16 |
| 4.2.2 Short-Circuit Protection with Delayed Trip (S)..... | 17 |
| 4.2.3 Instantaneous Short-Circuit Protection (I)..... | 19 |
| 4.2.4 Ground-Fault Protection (G)..... | 20 |
| 4.2.5 Electronic Trip Units for Tmax Circuit Breakers..... | 21 |
| 4.2.5.1 Setting Examples of a Trip Unit PR222DS..... | 22 |
| 4.2.6 Electronic Trip Units for Emax Circuit Breakers..... | 24 |
| 5. Trip Curves of ABB Trip Units | |
| 5.1 Trip Curves of Thermal magnetic Trip Units | 25 |
| 5.2 Trip Curves of Electronic Trip Units..... | 26 |
| 5.2.1 Functions L and S | 26 |
| 5.2.2 Function I | 29 |
| 5.2.3 Function G..... | 30 |
| 6. Curves of Current Limiting Circuit Breakers: Let-Through Values of I^{2t} and Peak Current | 32 |
| Annex A: Tolerance in the Trip Curves | 35 |
| Glossary | 36 |

1. Introduction

This White Paper is to clarify the reading and the interpretation of the characteristic curves (trip curves, specific let-through energy curves and limitation curves) of the Molded-Case Circuit Breakers (MCCBs) and Low Voltage Power Circuit Breakers (LVPCBs) manufactured by ABB in compliance with the following Standards:

- UL 489: Molded-Case Circuit Breakers, Molded-Case Switches and Circuit Breaker Enclosures
- UL 1066: Low-Voltage AC and DC Power Circuit Breakers Used in Enclosures
- ANSI C37.13: IEEE Standard for Low-Voltage AC Power Circuit Breakers Used in Enclosures
- ANSI C37.16: Low-Voltage Power Circuit Breakers and AC Power Circuit Protectors. Preferred Ratings, Related Requirements, and Application Recommendations
- ANSI C37.17: American National Standard for Trip Devices for AC and General Purpose DC Low Voltage Power Circuit Breakers

This publication is divided into four parts.

The first part (Chapters 1 and 2) describes the purpose of this White Paper and all the useful definitions.

The second part (Chapter 3) provides an in depth look at ABB UL industrial circuit breakers.

The third part (Chapter 4) describes the trip units of ABB circuit breakers and the characteristic trip curves.

Finally, the fourth part (Chapters 5 and 6) provides examples of curves to help comprehension and interpretation of the contained information.

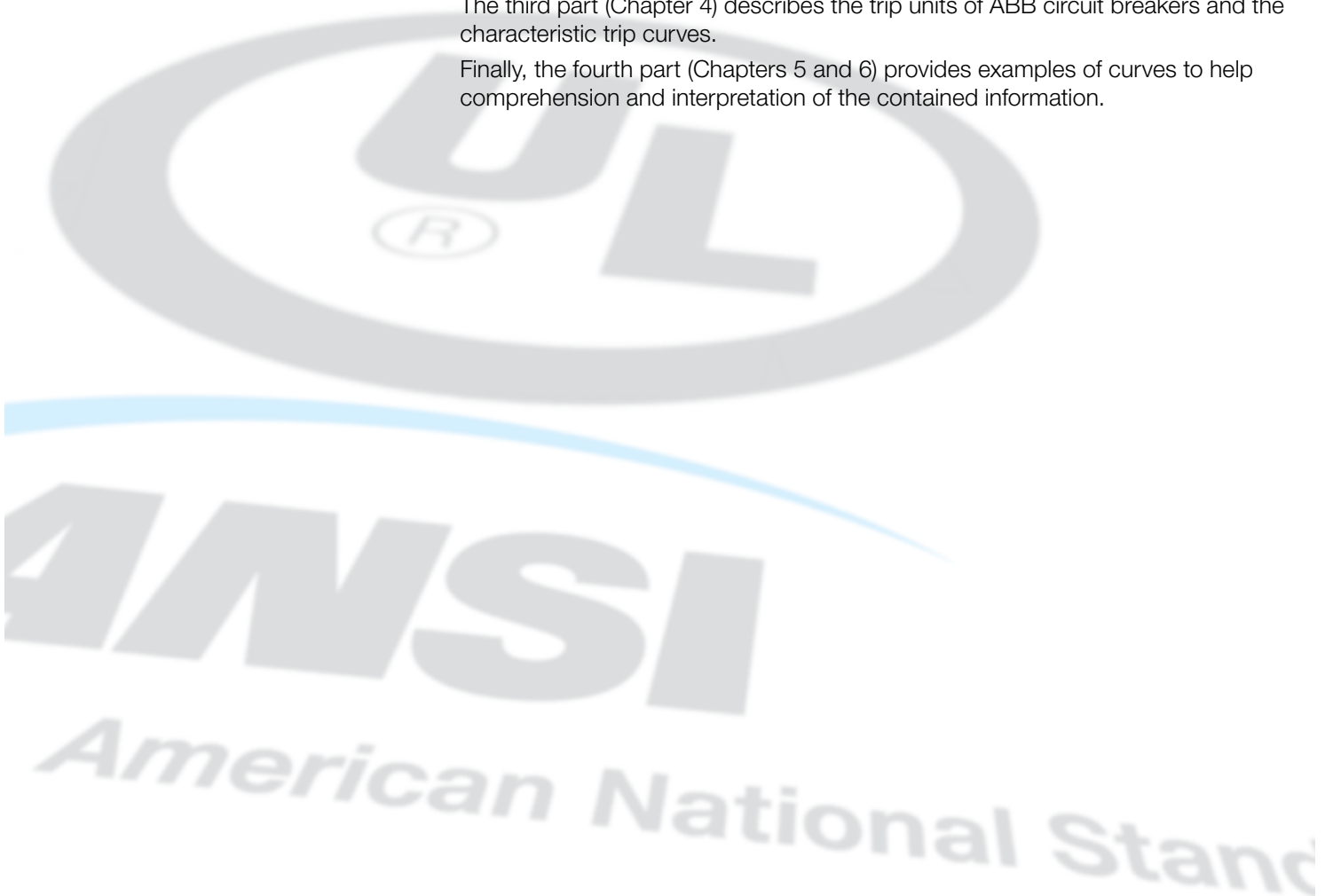

2. Main Definitions

The main definitions below are from the UL 489, UL 1066, ANSI C37.13 and ANSI C37.17 Standards.

Definitions from the Standard UL 489 (MCCB)



- 1 - **ADJUSTABLE CIRCUIT BREAKER:** a circuit breaker that has adjustable time/current tripping characteristics. These may include:
 - a) Inverse-time (such as continuous current, long time, and/or short time);
 - b) Instantaneous;
 - c) Ground-fault.
- 2 - **ADJUSTABLE INSTANTANEOUS RELEASE (TRIP):** that part of an over-current trip element that can be adjusted to trip a circuit breaker instantaneously at various values of current within a predetermined range of currents.
- 3 - **CIRCUIT BREAKER:** a device designed to open and close a circuit by non-automatic means, and to open the circuit automatically on a predetermined overcurrent, without damage to itself when properly applied within its rating.
- 4 - **CIRCUIT BREAKERS WITH GROUND-FAULT PROTECTION FOR EQUIPMENT:** circuit breakers that perform all normal circuit breaker functions and also trip when a fault current to ground exceeds a predetermined value.
- 5 - **CURRENT-LIMITING CIRCUIT BREAKER:** one that does not employ a fusible element and, when operating within its current-limiting range, limits the let-through I^2t (see definition 20 AMPERES SQUARED SECONDS) to a value less than the I^2t of a 1/2-cycle wave of the symmetrical prospective current.

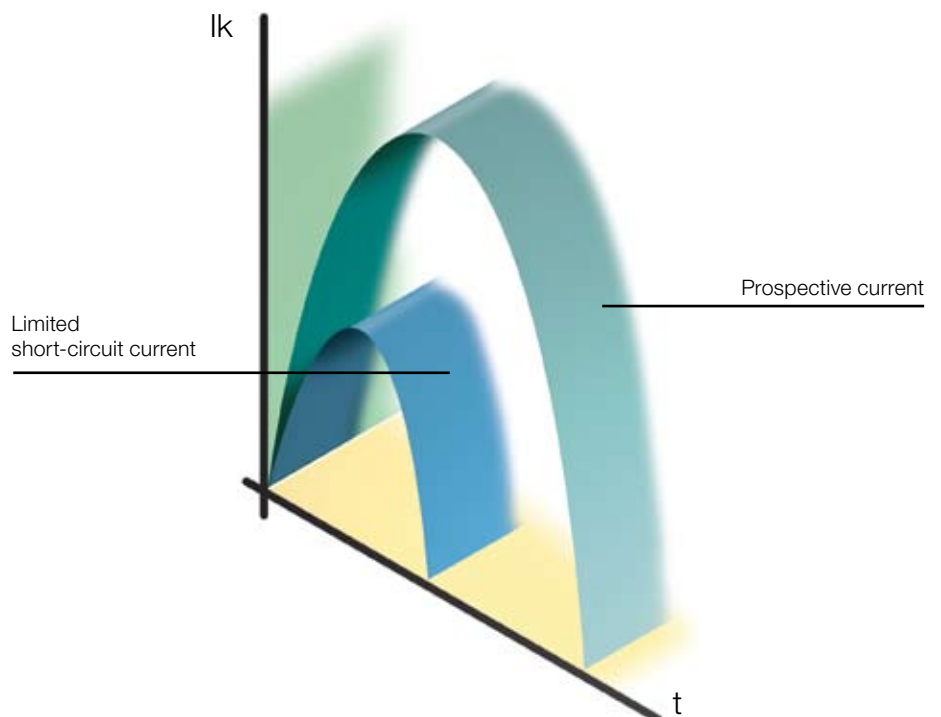

- 6 - **CURRENT-LIMITING RANGE**: the RMS symmetrical prospective currents between the threshold current and the maximum interrupting rating current.
- 7 - **CURRENT SETTING (I_r)**: the RMS current an adjustable circuit breaker is set to carry continuously without tripping. It is normally expressed as a percentage of the rated current and is adjustable.
- 8 - **FIXED INSTANTANEOUS RELEASE (TRIP)**: that part of an overcurrent release element which contains a nonadjustable means that is set to trip a circuit breaker instantaneously above a predetermined value of current.
- 9 - **FRAME**: an assembly consisting of all parts of a circuit breaker except an interchangeable trip unit.
- 10 - **FRAME SIZE**: a term applied to a group of circuit breakers of similar physical configuration. Frame size is expressed in amperes and corresponds to the largest ampere rating available in the group. The same frame size designation may be applied to more than one group of circuit breakers.
- 11 - **GROUND-FAULT DELAY**: an intentional time delay in the tripping function of a circuit breaker when a ground-fault occurs.
- 12 - **GROUND-FAULT PICKUP SETTING**: the nominal value of the ground-fault current at which the ground-fault delay function is initiated.
- 13 - **INSTANTANEOUS OVERRIDE**: a fixed current level at which an adjustable circuit breaker will override all settings and will trip instantaneously.
- 14 - **INSTANTANEOUS PICKUP SETTING**: the nominal value of current that an adjustable circuit breaker is set to trip instantaneously.
- 15 - **INSTANTANEOUS TRIP**: a qualifying term indicating that no delay is purposely introduced in the automatic tripping of the circuit breaker.
- 16 - **INSTANTANEOUS TRIP CIRCUIT BREAKER (MOTOR CIRCUIT PROTECTOR OR CIRCUIT INTERRUPTER)**: is one intended to provide short circuit protection only. Although acting instantaneously under short circuit conditions, these circuit breakers are permitted to include a transient dampening action to ride through initial motor transients.
- 17 - **INTERCHANGEABLE TRIP UNIT**: one which can be interchanged by a user among circuit breaker frames of the same design (to see also definition 32 RATING PLUG).
- 18 - **INTERRUPTING RATING**: the highest current at rated voltage that a device is intended to interrupt under standard test conditions.
- 19 - **INVERSE TIME**: a qualifying term indicating that there is a purposely introduced delayed tripping in which the delay decreases as the magnitude of the current increases.
- 20 - **I^2t (AMPERES SQUARED SECONDS)**: an expression related to the circuit energy as a result of current flow. With respect to circuit breakers, the I^2t [A^2s] is expressed for the current flow between the initiation of the fault current and the clearing of the circuit.
- 21 - **LONG-TIME DELAY**: an intentional time delay in the overload tripping of an adjustable circuit breaker's inverse time characteristics. The position of the long time portion of the trip curve is normally referenced in seconds at 600 percent of the current setting (I_r).
- 22 - **LONG-TIME PICKUP**: the current at which the long-time delay function is initiated.
- 23 - **MOLDED-CASE CIRCUIT BREAKER**: a circuit breaker which is assembled as an integral unit in a supportive and enclosed housing of insulating material.

- 24 - **OVERCURRENT**: Any current in excess of the rated current of equipment or the ampacity of a conductor. It may result from overload, short-circuit, or ground-fault.
- 25 - **OVERLOAD**: Operation of equipment in excess of normal, full-load rating or of a conductor in excess of rated ampacity that, when it persists for a sufficient length of time, would cause damage or dangerous overheating.
- 26 - **PEAK CURRENT**: the maximum instantaneous current that flows in a circuit.

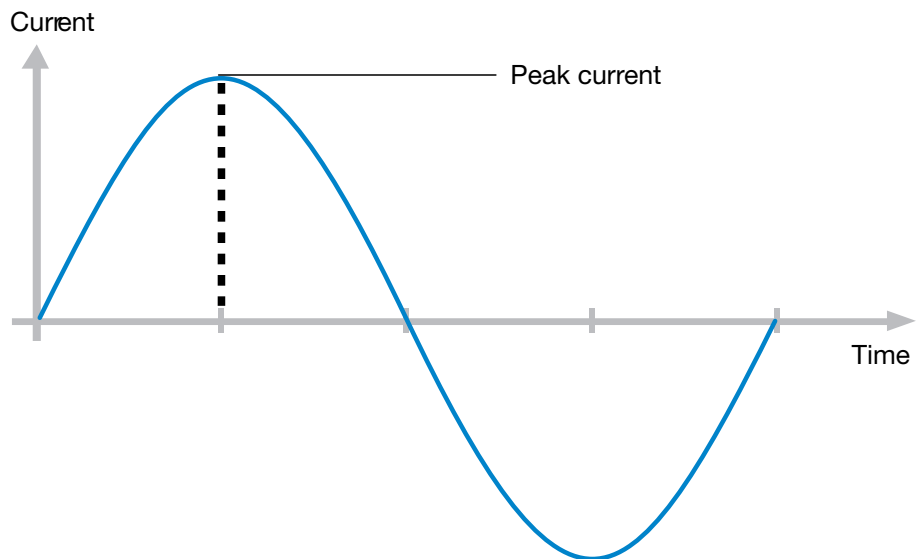

- 27 - **PROSPECTIVE CURRENT (AVAILABLE CURRENT)**: the current that which would flow in a circuit if a short circuit of negligible impedance were to occur at a given point.
- 28 - **RATED CURRENT (I_n)**: the marked current rating and the maximum RMS current a circuit breaker can carry continuously without tripping and the maximum current the circuit breaker will carry without changing, deleting, or adding a part or parts such as trip units and rating plugs. See also current setting (I_r).
- 29 - **RATED FREQUENCY**: the service frequency of the circuit for which the circuit breaker is designed and tested.
- 30 - **RATED VOLTAGE**: the rated voltage is the nominal RMS voltage for which the circuit breaker is designed to operate.
- 31 - **RATING**: the designated limit or limits of the rated operating characteristic(s) of a device.
- 32 - **RATING PLUG**: a self-contained portion of a circuit breaker that is interchangeable and replaceable in a circuit breaker trip unit by the user. It sets the RATED CURRENT (I_n) of the circuit breaker.
- 33 - **SHORT CIRCUIT**: An abnormal connection (including an arc) of relatively low impedance, whether made accidentally or intentionally, between two points of different potential.

- 34 - **SHORT CIRCUIT CURRENT RATING**: the maximum RMS prospective (available) current to which a device can be connected when protected by the specified overcurrent protective devices. The rating is expressed in amperes and volts.
- 35 - **SHORT-TIME DELAY**: an intentional time delay in the tripping of a circuit breaker between the overload and the instantaneous pickup settings.
- 36 - **SHORT-TIME PICKUP**: the current at which the short-time delay function is initiated.
- 37 - **THRESHOLD CURRENT** – the RMS symmetrical prospective current at the threshold of the current limiting range, where:
 - a) the peak current let-through in each phase is less than the peak of that symmetrical prospective current, and
 - b) the I^2t in each phase is less than the I^2t of a 1/2 cycle wave of the symmetrical prospective current.
- 38 - **TRIPPING**: the opening of a circuit breaker by actuation of the release mechanism.
- 39 - **TRIP UNIT**: a self-contained portion of a circuit breaker that is interchangeable and replaceable in a circuit breaker frame by the user. It actuates the circuit breaker release mechanism and it sets the RATED CURRENT (I_n) of the circuit breaker unless a rating plug is used (to see also definition 32 RATING PLUG).



Definitions from the Standards ANSI C37.13 and ANSI C37.17

- 40 - **DIRECT-ACTING OVERCURRENT ELECTRONIC TRIP DEVICE⁽¹⁾** : a release or tripping system that is completely self contained in a circuit breaker and which requires no external power or control circuits to cause it to function, and is activated by means of analog or digital processing of a sampling of the current flowing through the circuit breaker. Information functions, if provided, may require external power and/or control circuits. The direct-acting overcurrent trip devices may include ground trip elements.
- 41 - **RATED MAXIMUM VOLTAGE**: the rated maximum voltage of a circuit breaker is the highest rms voltage, three-phase or single-phase, at which it is designed to perform. The circuit breaker shall be rated at one or more of the following maximum voltages: 635V, 508V, or 254V. For fused circuit breakers, the 635V rated maximum voltage becomes 600V to match the fuse rating.
- 42 - **RATED FREQUENCY**: the rated frequency of a circuit breaker is the frequency at which it is designed to perform. The standard frequency is 60Hz. Application at other frequencies should receive special consideration.
- 43 - **RATED CONTINUOUS CURRENT**: the rated continuous current of a circuit breaker is the designated limit of rms current at rated frequency that it shall be required to carry continuously without exceeding the temperature limitations designated in Section 7 (in ANSI C37.13). The preferred continuous current ratings of the various frame sizes are listed in ANSI C37.16-1988. The rated continuous current of a circuit breaker equipped with direct-acting trip devices or fuses of a lower rating than the frame size of the circuit breaker is determined by the rating of those devices.

⁽¹⁾ In this document the direct-acting overcurrent electronic trip device, installed in the Low Voltage Power Circuit Breakers, is called electronic trip unit.

3. Complying with the Standards UL 489 and UL 1066

3.1 Generalities on Low Voltage Circuit Breakers

An electric system shall be protected by the damages which may result from overcurrents. An overcurrent can be divided into:

- Short circuit (see definition 33 Chapter 2);
- Overload (see definition 25 Chapter 2).

In both cases (short circuit as well as overcurrent), the cables overheat and, if there is not adequate protection, the temperature rise damages the electrical system and the connected equipment, with the risk of causing fires and subsequent serious damage to people and things.

Among overcurrent protective devices used as protection against overcurrents, there are circuit breakers which, in case of fault, open the circuit based on their tripping characteristics and on the overcurrent value.

The circuit breaker is a mechanical switching device, capable of making, carrying, and breaking current under normal circuit conditions and also, making and carrying for a specified time and breaking current under specified abnormal circuit conditions such as those of short circuit.

Each circuit breaker is equipped with a trip unit which actuates the circuit breaker release mechanism and allows opening on the basis of the current flowing through it.

Two types of trip units are used in low voltage circuit breakers:

- thermal magnetic (thermal magnetic trip unit)
- electronic (electronic trip unit)

The thermal magnetic trip unit consists of two parts:

- the thermal trip unit: made up of a bimetallic thermal device which actuates the opening of a circuit breaker with a delay depending on the overcurrent value; for overload protection
- the magnetic trip unit: made up of an electromagnetic device, with a fixed (fixed instantaneous trip) or adjustable (adjustable instantaneous trip) threshold, which actuates the instantaneous trip of the circuit breaker on a pre-determined overcurrent value (multiple of the I_n) with a constant trip time (about some tens of milliseconds) for short circuit protection.

Thermal magnetic trip unit

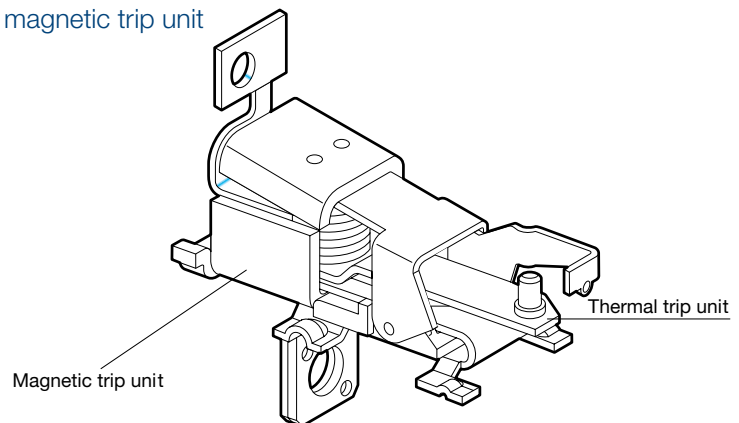

The electronic trip units instead use a microprocessor to process the current signal and opening in case of fault. By digital processing of the signal, they provide the following protection functions:

- the long time-delay trip function (ANSI code: 51, AC time overcurrent relay);
- the short time-delay trip function (ANSI code: 51, AC time overcurrent relay);
- the instantaneous trip function (ANSI code: 50, instantaneous overcurrent relay);
- the ground-fault trip function (ANSI code: 51 N, AC time ground fault overcurrent relay).

3.2 ABB Low Voltage Circuit Breakers

ABB offers the following circuit breaker types:

- Low Voltage Molded Case Circuit Breakers (MCCBs) of Tmax series, for rated currents from 15A up to 3000A.
- the Low Voltage Power Circuit Breakers (LVPCBs) of Emax series, for rated continuous currents in a range from 400A to 5000A.

These devices are described, focusing on the trip units (thermal magnetic and electronic) with which they are equipped.

3.2.1 Molded-Case Circuit Breakers (Tmax)

The circuit breakers of Tmax series (T1 1P, T1, T2, T3, T4, T5, T6, T7 and T8) are designed complying with the Standards UL 489 and can be applied in installations with currents from 15 to 3000A, with rated voltages of 240V, 277V, 480V, 600Y/347V and 600VAC.

Depending on short circuit requirements, Tmax can be chosen per the table below.



| Type | | Tmax T1 1p | Tmax T1 | Tmax T2 | Tmax T3 | Tmax Ts3 | Tmax Ts3 |
|-----------------------------|-----------------------------|------------|----------|----------|----------|------------|------------|
| Frame size | [A] | 100 | 100 | 100 | 225 | 150 | 225 |
| Number of poles | [Nr] | 1 | 3-4 | 3-4 | 3-4 | 2-3-4 | 2-3-4 |
| Rated voltage | AC (50-60Hz) | 347 | 600Y/347 | 480 | 600Y/347 | 600 | 480 |
| | DC | [V] | 500 | | 500 | 600 | 500 |
| Interrupting ratings | | B | N | S H | N S | N H L | N H L |
| | 240V AC | [kA rms] | 50 ② | 65 150 | 50 65 | 65 100 150 | 65 100 150 |
| | 277V AC | [kA rms] | 18 ① | | | | |
| | 347V AC | [kA rms] | 14 ① | | | | |
| | 480V AC | [kA rms] | | 22 ② | 35 65 | 25 35 | 25 50 85 ⑤ |
| | 600Y/347V AC | [kA rms] | | 10 | | 10 10 | |
| | 600V AC | [kA rms] | | | | | 14 14 25 |
| | 250V DC (2 poles in series) | [kA rms] | | 25 | | 25 35 | |
| | 500V DC (3 poles in series) | [kA rms] | | 25 | | 25 35 | |
| | 500V DC (2 poles in series) | [kA rms] | | | | | 35 50 65 |
| 600V DC (3 poles in series) | [kA rms] | | | | | 20 35 50 | |
| Trip units | TMF | ■ | ■ | ■ | ■ | ■ | ■ |
| | TMD/TMA | | | | | | |
| | ELT | | | ■ | | | |
| | MA | | | ■ | ■ | ■ | ■ |
| | Electronic | | | ■ | | | |
| Dimensions | H | [in/mm] | 5.12/130 | 5.12/130 | 5.12/130 | 5.9/150 | 6.7/170 |
| | W 3p | [in/mm] | 1/25.4 | 3/76 | 3.54/90 | 4.13/105 | 4.13/105 |
| | D | [in/mm] | 2.76/70 | 2.76/70 | 2.76/70 | 2.76/70 | 4.07/103.5 |
| Mechanical life | [No. operations] | 25000 | 25000 | 25000 | 25000 | 25000 | 25000 |

① In15A = 10kA@277VAC 10kA@347VAC

② In15A = 35kA@240VAC 14kA@480Y/277 VAC

③ T5 600 with electronic trip units only and in three pole version

④ 2p breakers: available only in N interrupting rating

⑤ In from 15A up to 30A=65kA@480V AC

In addition, the circuit breakers Tmax T2H, T4H, T4V, T5H and T5V, are also Current Limiting Circuit Breakers (see definition 5 Chapter 2).

In these devices, the system adopted for electric arc extinguishing allows high short circuit currents to be interrupted in very short times. The remarkable speed of contacts opening and the structure of the arcing chamber contribute to the extinguishing of the arc in the shortest possible time, limiting the value of the let-through energy I^2t and allowing them to be Current Limiting Circuit Breakers.

For single phase applications, the single-pole circuit breaker T1B 1P, with interrupting rating of 18kA at 277Vac, is available.

Tmax series molded case circuit breakers can be equipped with both Thermal magnetic (TMF, TMD, TMA) as well as electronic (PR221DS, PR222DS/P and PR222DS/PD-A) trip units, whose main characteristics and functions shall be described in Chapter 4.

The molded case circuit breakers equipped with electronic trip units are not intended for DC systems.

The main characteristics of the protection devices of Tmax series are summarized in the following table:



| Type | | Tmax T4 | Tmax T5 | Tmax T6 | Tmax T7 | Insulated case T8 |
|--------------------------------------|--------------------------------------|--------------------|--------------------|----------------|------------------------------------|-------------------------|
| Frame size | [A] | 250 | 400-600 ③ | 800 | 1000-1200 | 1600, 2000, 2500 & 3000 |
| Number of poles | [Nr] | 2-3-4 ④ | 2-3-4 ④ | 3-4 | 3-4 | 3 |
| Rated voltage | AC (50-60Hz) [V] | 600 | 600 | 600 | 600 | 600 |
| | DC [V] | 600 | 600 | 600 | | |
| Interrupting ratings | | N S H L V | N S H L V | N S H L | S H L | T8V |
| | 240V AC [kA rms] | 65 100 150 200 200 | 65 100 150 200 200 | 65 100 200 200 | 65 100 150 | 125 |
| | 277V AC [kA rms] | | | | | |
| | 347V AC [kA rms] | | | | | |
| | 480V AC [kA rms] | 25 35 65 100 150 | 25 35 65 100 150 | 35 50 65 100 | 50 65 100 | 125 |
| | 600Y/347V AC [kA rms] | | | | | |
| | 600V AC [kA rms] | 18 25 35 65 100 | 18 25 35 65 100 | 20 25 35 42 | 25 50 65 | 100 |
| | 250V DC (2 poles in series) [kA rms] | | | | | |
| | 500V DC (3 poles in series) [kA rms] | | | | | |
| 500V DC (2 poles in series) [kA rms] | 25 35 50 65 100 | 25 35 50 65 100 | 35 35 50 65 | | | |
| 600V DC (3 poles in series) [kA rms] | 16 25 35 50 65 | 16 25 35 50 65 | 20 20 35 50 | | | |
| Trip units | TMF | ■ | | | | |
| | TMD/TMA | ■ | ■ | ■ | | |
| | ELT | | | | | |
| | MA | | | | | |
| | Electronic | ■ | ■ | ■ | ■ | |
| Dimensions | H [in/mm] | 8.07/205 | 8.07/205 | 10.55/268 | 10.55/268 | 15 / 382 |
| | W 3p [in/mm] | 4.13/105 | 5.51/140 | 8.26/210 | 8.26/210 | 16.8 / 427 |
| | D [in/mm] | 4.07/103.5 | 4.07/103.5 | 4.07/103.5 | 6.06/154 (toggle) 7/178 (motor) | 11.2 / 282 |
| Mechanical life | [No. operations] | 20,000 | 20,000 | 20,000 | 10,000 | 15,000 |

① In15A = 10kA@277 VAC 10kA@347 VAC

② In15A = 35kA@240 VAC 14kA@480Y/277 VAC

③ T5 600 with electronic trip units only and in three pole version-

④ 2p T4N250 and T5N400 available only in N interrupting capacity.

⑤ In from 15A up to 30A=65kA@480 VAC

⑥ Applies to MCS only.

Low Voltage Circuit Breakers

3.2.2 Low Voltage Power Circuit Breakers (Emax)

The family of Low Voltage Power Circuit Breakers which ABB offers, in compliance with Std. UL 1066, is formed by Emax CBs type E1, E2, E3, E4 and E6 which cover a range of currents from 400 to 5000A, at 635V (rated maximum voltage). These circuit breakers, with different levels of performance (B-A, N-A, S-A, H-A, V-A, L-A) and ampere ratings, are able to break short-circuit

| Common data | | |
|--------------------------------|------|--------------------------|
| Voltages | | |
| Rated maximum voltage | [V] | 635 |
| Rated voltage | [V] | 600 |
| Test voltage (1 min. 50/60 Hz) | [kV] | 2.2 |
| Frequency | [Hz] | 50 - 60 |
| Number of poles | | 3 - 4 |
| Version | | Fixed (F) - Draw out (W) |



| | | E1 | | E2 | | | |
|---|-------|------------|------|------|------------|------|------|
| | | B-A | N-A | B-A | N-A | S-A | H-A |
| Level of performance | | | | | | | |
| Currents | | | | | | | |
| Frame size | [A] | 800 | 800 | 1600 | 800 | 800 | 800 |
| | [A] | 1200 | 1200 | | 1200 | 1200 | 1200 |
| | [A] | | | | 1600 | 1600 | 1600 |
| | [A] | | | | | | |
| | [A] | | | | | | |
| Capacity of neutral pole for four-pole circuit breakers | [%Iu] | 100 | 100 | 100 | 100 | 100 | 100 |
| Rated short circuit current | | | | | | | |
| 240 V | [kA] | 42 | 50 | 42 | 65 | 65 | 85 |
| 480 V | [kA] | 42 | 50 | 42 | 50 | 65 | 85 |
| 600 V | [kA] | 42 | 50 | 42 | 50 | 65 | 65 |
| Rated short time current | | | | | | | |
| | [kA] | 42 | 50 | 42 | 50 | 65 | 65 |
| Trip units | | | | | | | |
| PR121/P | | ■ | ■ | ■ | ■ | ■ | ■ |
| PR122/P | | ■ | ■ | ■ | ■ | ■ | ■ |
| PR123/P | | ■ | ■ | ■ | ■ | ■ | ■ |
| Trip times | | | | | | | |
| Make time (max) | [ms] | 80 | 80 | 80 | 80 | 80 | 80 |
| Break time (I<ST current) (max) | [ms] | 70 | 70 | 70 | 70 | 70 | 70 |
| Break time (I>ST current) (max) | [ms] | 30 | 30 | 30 | 30 | 30 | 12 |
| Overall dimensions | | | | | | | |
| Fixed: H = 418 mm/16.46 in - D = 302 mm/11.89 in * | | | | | | | |
| W (3 poles/4 poles) | [mm] | 296/386 | | | 296/386 | | |
| W (3 poles/4 poles) | [in] | 11.65/15.2 | | | 11.65/15.2 | | |
| Draw out: H = 461 mm/18.15 in - D = 396.5 mm/15.61 in ** | | | | | | | |
| W (3 poles/4 poles) | [mm] | 324/414 | | | 324/414 | | |
| W (3 poles/4 poles) | [in] | 12.76/16.3 | | | 12.76/16.3 | | |
| Weights (Circuit breaker complete with trip unit, RH terminals, CS, excluding accessories) | | | | | | | |
| Fixed | | | | | | | |
| 3 poles/4 poles | [kg] | 45/54 | | | 50/61 | | |
| 3 poles/4 poles | [lbs] | 99/119 | | | 110/134 | | |
| Draw out | | | | | | | |
| 3 poles/4 poles | [kg] | 70/82 | | | 78/93 | | |
| 3 poles/4 poles | [lbs] | 154/181 | | | 172/205 | | |

(1) four poles only.
 * for E3X-A: H=438 mm/ 17.24 in - D=302 mm/ 11.89 in
 ** for E3X-A: H=481 mm/ 18.94 in - D=396.5 mm/ 15.61 in

| | | E1 B-A/N-A | | E2 B-A/N-A/S-A/H-A | | |
|--|-------------------------|------------|------|--------------------|------|------|
| Continuous current rating Iu | [A] | 800 | 1200 | 800 | 1200 | 1600 |
| Mechanical life with regular ordinary maintenance | [No. Operations x 1000] | 20 | 20 | 20 | 20 | 20 |
| Operation frequency | [Operations/hour] | 30 | 30 | 30 | 30 | 30 |
| Electrical life | [No. Operations x 1000] | 10 | 10 | 10 | 10 | 10 |
| Operation frequency | [Operations/hour] | 30 | 30 | 30 | 30 | 30 |

(2) 10 for E3X-A.
 (3) 1.5 for E3X-A.

Low Voltage Circuit Breakers

currents up to 200kA at 240V and 480V and up to 100kA at 600V. Emax CBs are equipped exclusively with electronic trip units and for this reason they are used only in AC systems. The main characteristics of the protection devices of Emax series are summarized in the following table:



| E3 | | | | | E4 | | | | | E6 | | | | | |
|------|-------------|------|---------|------|------|-------------|------|-------|----------------------|-------------|------|------|-------|----------------------|----------------------|
| N-A | S-A | H-A | V-A | X-A | S-A | H-A | V-A | L-A | H-A/f ⁽¹⁾ | H-A | V-A | L-A | X-A | H-A/f ⁽¹⁾ | X-A/f ⁽¹⁾ |
| 2000 | 800 | 800 | 800 | 800 | 3200 | 3200 | 3200 | 3200 | 3200 | 4000 | 4000 | 4000 | 4000 | 4000 | 4000 |
| 2500 | 1200 | 1200 | 1200 | 1200 | 3600 | 3600 | 3600 | 3600 | 3600 | 5000 | 5000 | 5000 | 5000 | 5000 | 5000 |
| | 1600 | 1600 | 1600 | 1600 | | | | | | | | | | | |
| | 2000 | 2000 | 2000 | 2000 | | | | | | | | | | | |
| | 2500 | 2500 | 2500 | | | | | | | | | | | | |
| | 3200 | 3200 | 3200 | | | | | | | | | | | | |
| 100 | 100 | 100 | 100 | 100 | 50 | 50 | 50 | 50 | 100 | 50 | 50 | 50 | 50 | 100 | 100 |
| 65 | 85 | 85 | 125 | 200 | 85 | 100 | 100 | 125 | 100 | 125 | 125 | 150 | 200 | 125 | 200 |
| 50 | 65 | 85 | 125 | 200 | 65 | 85 | 100 | 125 | 85 | 85 | 125 | 150 | 200 | 85 | 200 |
| 50 | 65 | 85 | 100 | 14 | 65 | 85 | 100 | 100 | 85 | 85 | 100 | 100 | 100 | 85 | 100 |
| 50 | 65 | 65 | 85 | 14 | 65 | 85 | 100 | 100 | 85 | 100 | 100 | 100 | 100 | 100 | 100 |
| ■ | ■ | ■ | ■ | ■ | ■ | ■ | ■ | ■ | ■ | ■ | ■ | ■ | ■ | ■ | ■ |
| ■ | ■ | ■ | ■ | ■ | ■ | ■ | ■ | ■ | ■ | ■ | ■ | ■ | ■ | ■ | ■ |
| ■ | ■ | ■ | ■ | ■ | ■ | ■ | ■ | ■ | ■ | ■ | ■ | ■ | ■ | ■ | ■ |
| 80 | 80 | 80 | 80 | 80 | 80 | 80 | 80 | 80 | 80 | 80 | 80 | 80 | 80 | 80 | 80 |
| 70 | 70 | 70 | 70 | 70 | 70 | 70 | 70 | 70 | 70 | 70 | 70 | 70 | 70 | 70 | 70 |
| 30 | 30 | 30 | 30 | 30 | 30 | 30 | 30 | 30 | 30 | 30 | 30 | 30 | 30 | 30 | 30 |
| | 404/530 | | | | | 566/656 | | 746 | | 782/908 | | | 1034 | | |
| | 15.91/20.82 | | | | | 22.28/25.83 | | 29.37 | | 30.79/35.78 | | | 40.71 | | |
| | 432/558 | | | | | 594/684 | | 774 | | 810/936 | | | 1062 | | |
| | 17.01/21.97 | | | | | 23.39/26.93 | | 30.47 | | 31.89/36.85 | | | 41.81 | | |
| | 66/80 | | 70/84 | | | 97/117 | | 125 | | 140/160 | | | 185 | | |
| | 145/176 | | 154/185 | | | 214/258 | | 276 | | 308/353 | | | 408 | | |
| | 104/125 | | 106/128 | | | 147/165 | | 200 | | 210/240 | | | 275 | | |
| | 229/275 | | 233/282 | | | 324/363 | | 441 | | 463/529 | | | 607 | | |

| E3 N-A/S-A/H-A/V-A | | | | | | E4 S-A/H-A/V-A/L-A/H-A/f | | | E6 H-A/V-A/L-A/X-A/H-A/f/X-A/f | |
|--------------------|-------------------|-------------------|-------------------|------|------|--------------------------|------|--|--------------------------------|------|
| 800 | 1200 | 1600 | 2000 | 2500 | 3200 | 3200 | 3600 | | 4000 | 5000 |
| 15 ⁽²⁾ | 15 ⁽²⁾ | 15 ⁽²⁾ | 15 ⁽²⁾ | 15 | 15 | 8 | 8 | | 8 | 8 |
| 30 | 30 | 30 | 30 | 30 | 30 | 30 | 30 | | 30 | 30 |
| 10 ⁽³⁾ | 10 ⁽³⁾ | 10 ⁽³⁾ | 8 ⁽³⁾ | 8 | 8 | 5 | 5 | | 5 | 3 |
| 30 | 30 | 30 | 30 | 30 | 30 | 30 | 30 | | 30 | 30 |

4. Thermal magnetic and Electronic Trip Units

In this chapter the characteristics, protection functions and trip curves of the thermal magnetic and electronic trip units used on ABB circuit breakers are described.

4.1 Thermal magnetic Trip Units

Thermal magnetic trip units are devices which provide combined protection against overload and short-circuit.

This type of trip unit is used for: AC/DC power distribution, electrical equipment protection (transformers, motors, generators) and capacitor protection.

ABB thermal magnetic trip units are mounted on MCCBs Tmax only and offer the following protections:

4.1.1 Overload Protection (L)

The protection against overloads is provided by a thermal device with inverse time trip characteristic. Identified by the letter “L”, it is a protection that trips when the fault current exceeds threshold I_1 , either, adjustable or fixed, according to the type of trip unit.

The application range of this protection concerns all the installations which can be subject to low-value but long-time overcurrents, which are dangerous for the equipment and cables.

4.1.2 Instantaneous Short Circuit Protection (I)

The protection against short circuit is provided by a magnetic device with a trip time independent of the fault current value. Identified by the letter “I”, it is a protection that trips instantaneously when the fault current exceeds threshold I_3 , either, adjustable or fixed, according to the type of trip unit. This protection trips to quickly eliminate high value currents with no intentional delay.

4.1.3 Thermal magnetic Trip Units for Tmax Circuit Breakers

As regards Tmax CBs, ABB offers three different types of Thermal magnetic trip units (TMF, TMD and TMA). The protections and the trip thresholds are shown in the following table:

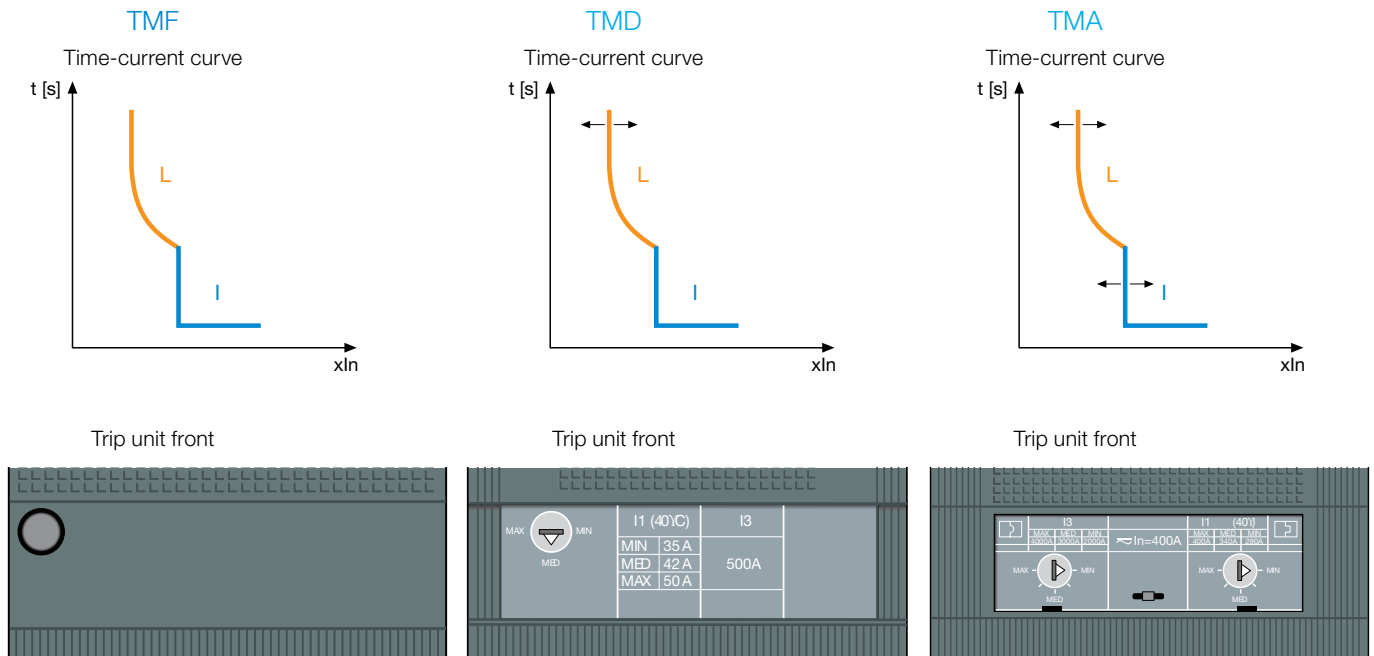

- | | | |
|--|---|---|
| <ul style="list-style-type: none"> - Overload protection "L" Thermal trip threshold: $I_1 = I_n$ - Short-circuit protection "I" Magnetic trip threshold: $I_3 = 10 \times I_n$ | <ul style="list-style-type: none"> - Overload protection "L" Thermal trip threshold: $I_1 = (0.7-1) \times I_n$ - Short-circuit protection "I" Magnetic trip threshold: $I_3 = 10 \times I_n$ | <ul style="list-style-type: none"> - Overload protection "L" Thermal trip threshold: $I_1 = (0.7-1) \times I_n$ - Short-circuit protection "I" Magnetic trip threshold: $I_3 = (5-10) \times I_n$ |
|--|---|---|

For circuit breakers Tmax T2 and T3, magnetic only trip units, MA, with adjustable threshold, are also available; they, complying with Standard UL 508 "Industrial Control Equipment", can be used in a "Combination Motor Controller Type D" (Instantaneous-Trip Circuit Breaker + Magnetic Motor Controller + Overload Relay).

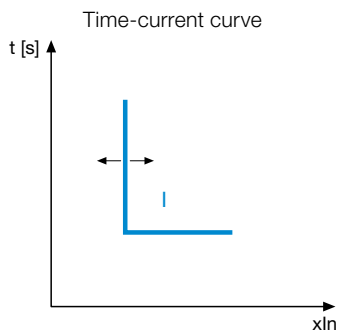

Trip unit front

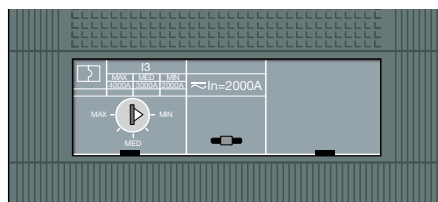

- Short-circuit protection "I"
Magnetic trip threshold: $I_3 = (6-12) \times I_n$

Thermal magnetic and electronic trip units

4.1.3.1 Time-Current Curve of a Thermal magnetic trip unit TMA

The curve, linked to the constructional characteristics of the Trip Unit, can be obtained through experimental tests and is graphically shown, in bilogarithmic scale, in a Cartesian system where the current I (in kA) and time t (in seconds) are plotted on the abscissa and on the ordinate respectively.

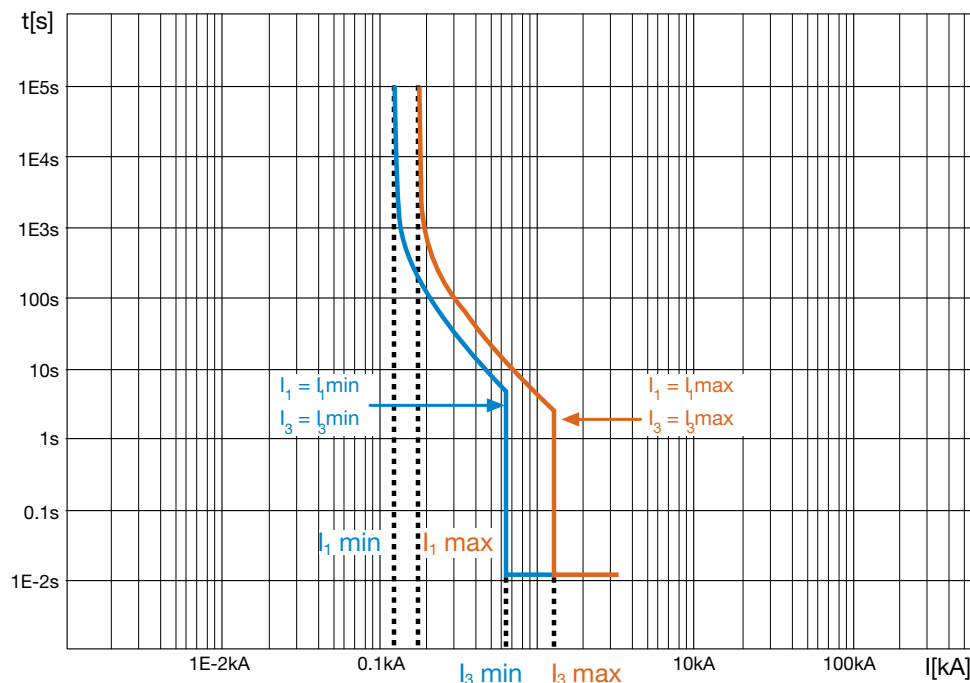

The graph shows two characteristic trip curves associated to the same trip unit TMA, where:

- the blue curve is that obtained by setting the thermal threshold I_1 and the magnetic threshold I_3 at their minimum value;
- the brown curve is that obtained by setting the two thresholds I_1 and I_3 at their maximum value.

Thermal magnetic and electronic trip units

4.1.3.2 Setting Examples of a Trip Unit TMA

The setting of the trip thresholds – thermal (I_1) and magnetic (I_3) - is obtained by setting relevant dials on potentiometers (see Figure 1).

As regards the setting of threshold I_1 , known the current I_b absorbed by the load and the I_n of the trip unit, results in:

$$\text{Setting}_L = \frac{I_b}{I_n}$$

The setting immediately higher than or equal to the obtained value shall be used. To set magnetic or threshold I_3 , knowing the minimum short-circuit current I_{kmin} of the system and the I_n of the trip unit, results in:

$$\text{Setting}_I = \frac{I_{kmin}}{I_n}$$

The setting immediately lower than or equal to the value obtained shall be used to satisfy the condition $I_3 \leq I_{kmin}$.

Example:

Circuit breaker T5N400 I_n 400 equipped with a TMA 400-4000

$I_b = 340A$

$I_{kmin} = 3000A$

$$\text{Setting}_L = \frac{340}{400} = 0.85 \rightarrow I_1 = 0.85 \times 400 = 340A$$

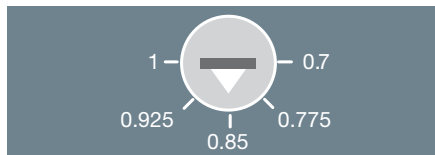

NOTE: this picture of the thermal threshold trimmer is for illustrative purpose only.

$$\text{Setting}_I = \frac{3000}{400} = 7.5 \rightarrow I_3 = 7.5 \times 400 = 3000A$$

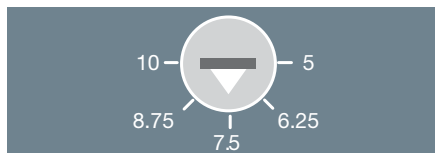

NOTE: this picture of the thermal threshold trimmer is for illustrative purpose only

Figure 1: Front of the trip unit TMA 400-4000

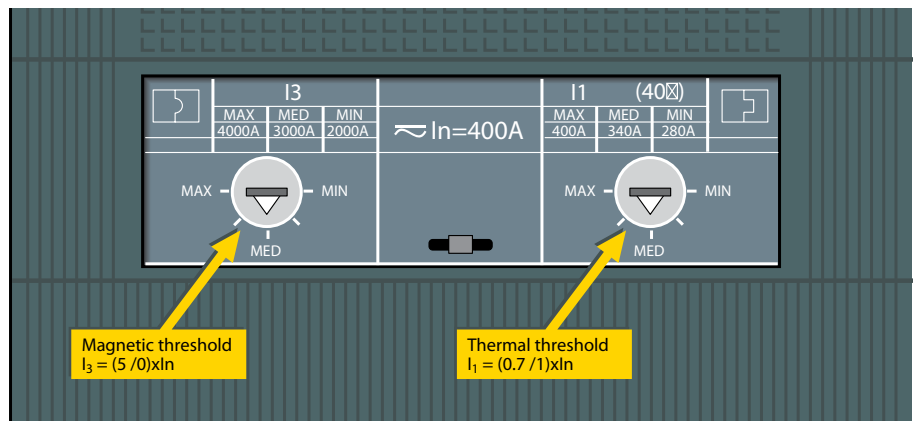

4.2 Electronic Trip Units

Electronic trip units are overcurrent protection based on microprocessor electronics. Compared with Thermal magnetic trip units, they allow precise setting both in terms of current providing more accurate protection. ABB electronic trip units, which are available on Tmax and Emax CBs, use the following protection functions.

4.2.1 Overload Protection (L)

Protection against overloads (long time delay trip function, ANSI code 51, AC time overcurrent relay), is identified by Function L. If the fault current exceeds the set threshold I_1 , this protection trips according to an inverse time characteristic, where the link time-current is represented by the relation $I^2t = K$ (constant let-through energy); with this curve, the tripping time decreases as the current increases.

I_1 represents the adjustable value of the trip threshold of the thermal protection and it is called long time pickup. This protection cannot be excluded. The inverse time characteristic curve of function L is graphically represented, in bilogarithmic scale as shown in Figure 2.

Figure 2: Trip curve with inverse time curve ($I^2t = K$) of protection L of a Tmax

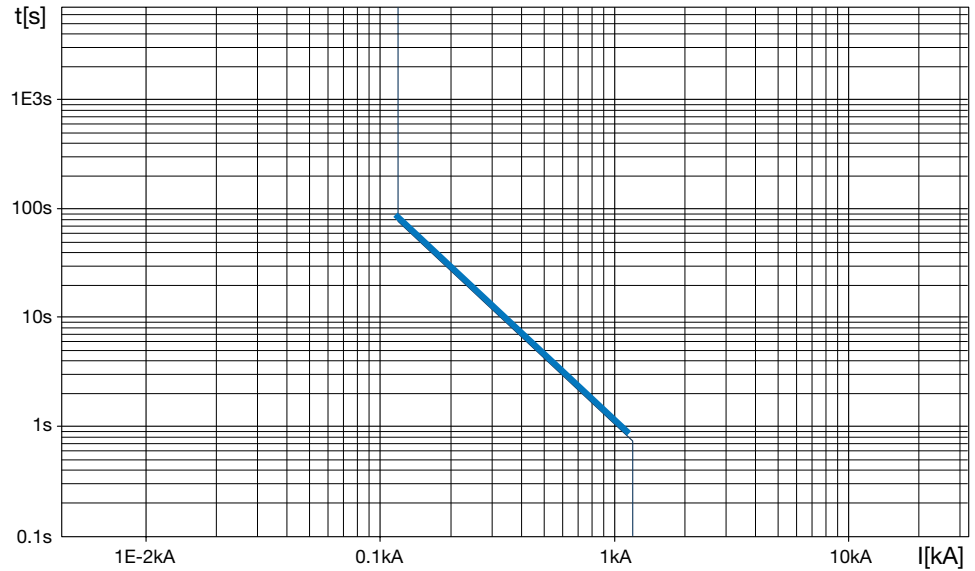

The electronic trip unit makes many possible trip settings available for Function L, more precisely, a bundle of parallel lines. Each line is identified by a time t_1 (the long time delay) which represents the trip time of the protection, in seconds, in correspondence with a multiple of I_1 . This multiple depends on the trip unit and is equal to $3 \times I_1$ for Emax CBs and $6 \times I_1$ for Tmax CBs.

To explain this concept, consider a molded-case circuit breaker Tmax T4N250, equipped with an electronic trip unit PR222DS/P In 100, set at $I_1=1 \times I_n=100\text{A}$ ($6 \times I_1=600\text{A}$). PR222DS/P allows four trip curves corresponding to a time t_1 of 3, 6, 9 and 18s at $6 \times I_1$ (see Figure 3).

Figure 3: Trip curves of function L of a trip unit PR222DS/P In 100

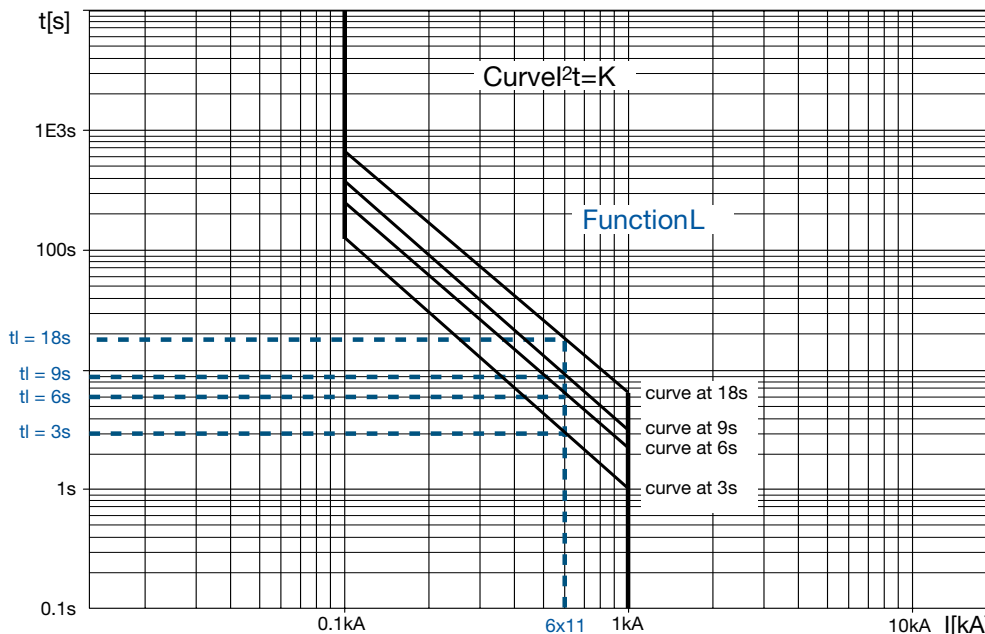

4.2.2 Short Circuit Protection with Delayed Trip (S)

Protection against short circuit with time delay trip (short time delay trip function, ANSI code 51, AC time overcurrent relay), is identified by Function S. If the fault current exceeds the set threshold I_2 , the protection trips with the following characteristic:

- with inverse time according to the relation $I^2t = K$: with this curve, the higher the fault current is, the shorter is the trip time;
- or
- with constant time delay according to the relation $t = K$: with this curve the trip time is independent of the current.

I_2 represents the adjustable value of the protection trip threshold called short time pickup. This protection can be excluded.

Curves $t=K/I^2$ (constant let-through energy)

As regards the trend of the curve, from a conceptual point of view, the considerations made for protection L remain valid, except for the fact that the characteristic trip curve of protection S passes through a point (I, t) identified by the time t_2 (the short time delay) which represents the trip time of the protection, in

seconds, in correspondence with a multiple of rated current I_n . This multiple of I_n depends on the trip unit and is equal to $10 \times I_n$ for E_{max} and $8 \times I_n$ for T_{max} .

Figure 4: Trip curves of function S (I^2t ON) of a trip unit PR222DS/P I_n 250

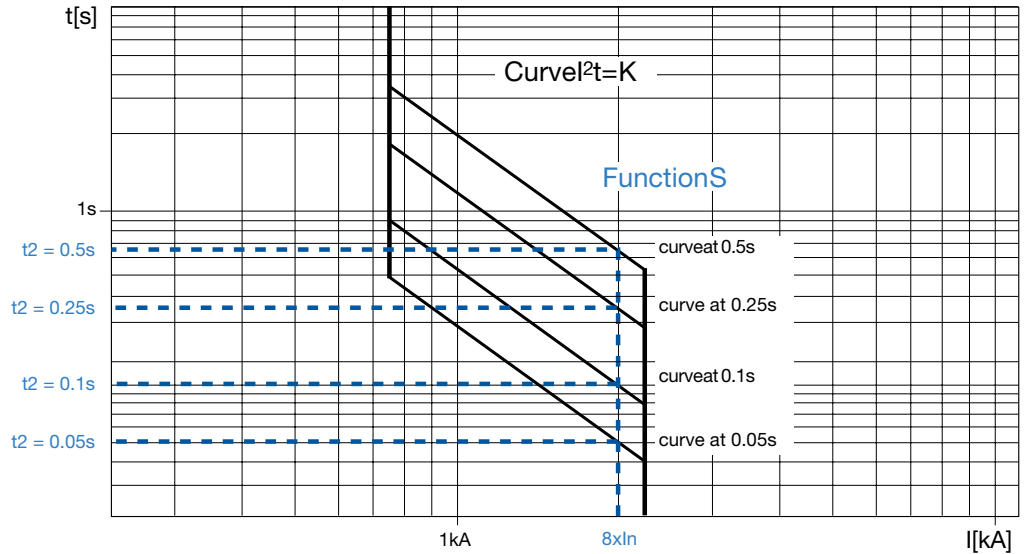

Curves $t=K$ (constant time)

Protection S with constant time delay is characterized by the same short time delay, t_2 (adjustable), for all fault currents higher than or equal to the short time pickup, I_2 . Considering T_{max} T4N250 equipped with a trip unit PR222DS/P I_n 100, turn OFF the curve $I^2t=K$ of function S (thus, four trip curves at $t=K$ become available, corresponding to a time t_2 of 0.05, 0.1, 0.25 and 0.5s).

Then set the following values for Function S:

$$I_2 = 6.40 \times I_n = 6.40 \times 100 = 640A \text{ (short time pickup)}$$

$$t_2 = 0.10s \text{ (short time delay)}$$

The curve which is obtained is shown with an orange line in Figure 5.

Figure 5: Trip curves at 0.1s and 0.5s for function S (I^2t OFF) of a trip unit PR222DS/P I_n 100

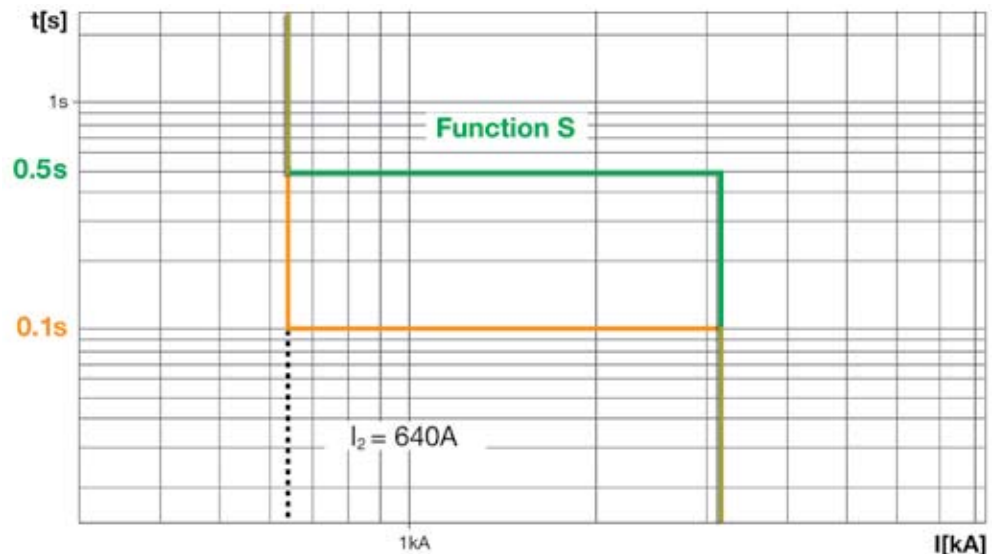

By changing the short time delay from 0.1s to 0.5s, the green curve is used. For fault currents higher or equal to the threshold I_2 of 640A, the protection function shall trip within the set time t_2 .

For another example of curve reading, see Chapter 5.

4.2.3 Instantaneous Short Circuit Protection (I)

The instantaneous protection against short circuit (instantaneous trip function, ANSI code 50, instantaneous overcurrent relay) is identified by Function I. If the fault current exceeds the set threshold value I_3 , the function initiates the instantaneous opening of the circuit breaker.

I_3 represents the adjustable value of the trip threshold of the protection, called instantaneous pickup setting.

If function I is turned off during a short-circuit, the release mechanism will trip at the instantaneous override of the circuit breaker.

The part of curve associated to this protection is the blue one in Figure 6.

Figure 6: Protection functions L-I

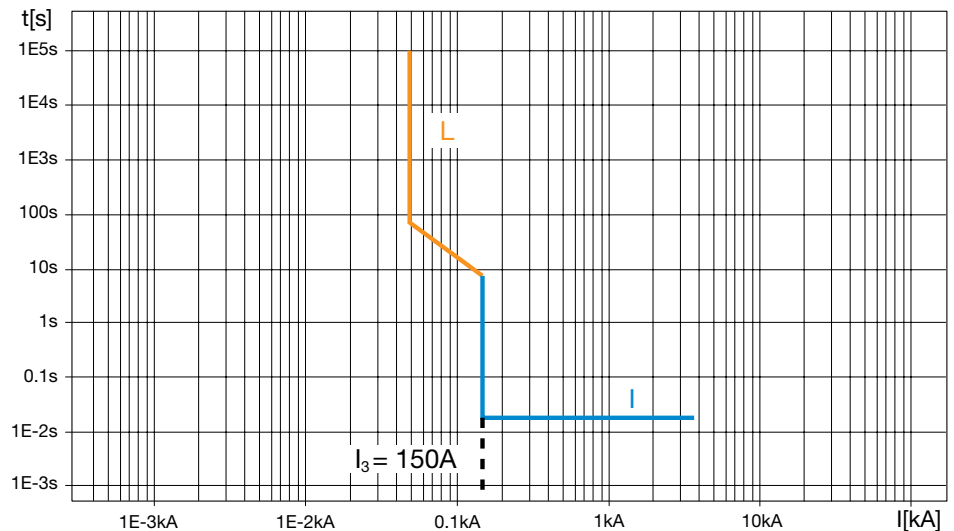

The graph represents the trip curve L-I of a circuit breaker Tmax T4N250 equipped with an electronic trip unit PR 222DS/P-LSIG In 100.

To find another example of reading the curve, refer to Chapter 5.

Figure 7: Typical time-current curve for electronic trip circuit breaker (I^2t ON)

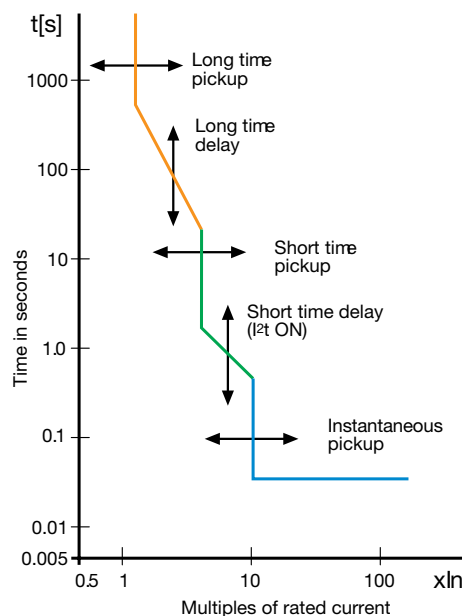
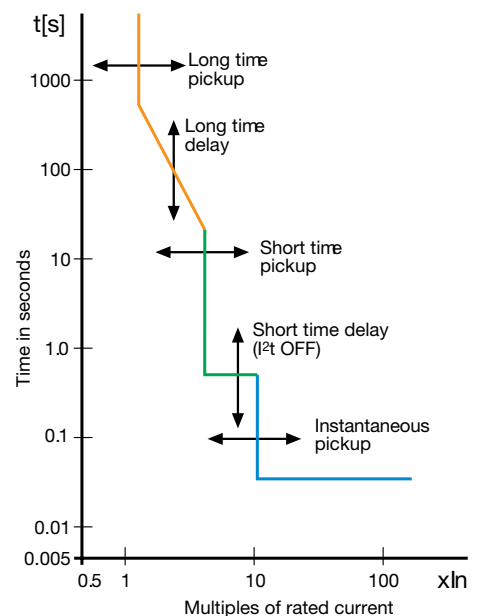

Figure 8: Typical time-current curve for electronic trip circuit breaker (I^2t OFF)



4.2.4 Ground-Fault Protection (G)

The most advanced electronic trip units have an integrated protection against ground faults (ground-fault trip function, ANSI code 51 N, AC time ground fault overcurrent relay) identified with the Function G.

It is a protection against ground fault with curve $I^2t = K$ or curve $t = K$. The parameters of this function are: the ground-fault pickup setting (I_d) and the ground fault-delay (t_d).

As regards the trip curves, which are illustrated in Figure 9, the concepts mentioned previously for protection S are valid.

This function protects against ground fault, since it addresses situations in which the fault current has such values that phase protections (L, S, I) are not actuated.

Function G is deactivated for fault currents higher than a multiple of I_n (variable according to the trip unit). This protection can be turned off.

Figure 9: Trip curves of function G

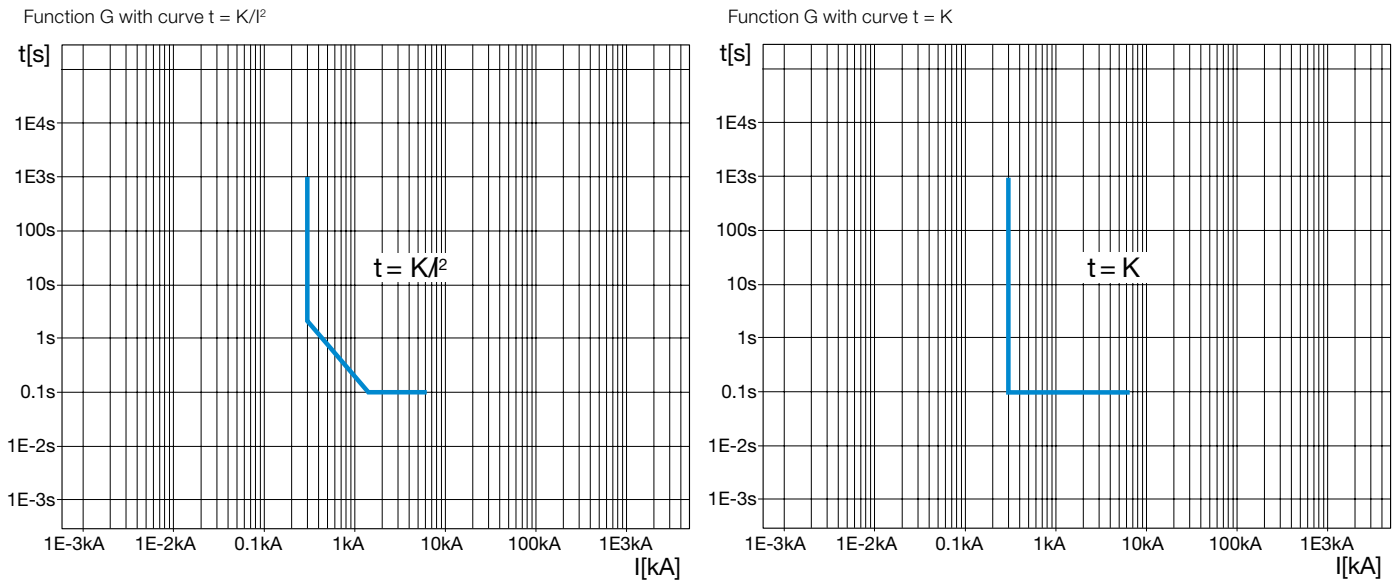

4.2.5 Electronic Trip Units for Tmax Circuit Breakers

For Tmax MCCBs, ABB offers three different versions of trip units:

- PR221DS-LS/I for T2, T4, T5 and T6;
- PR222DS/P for T4, T5 and T6;
- PR222DS/PD-A for T4, T5 and T6, with the dialogue unit to allow the circuit breakers to communicate on a network using the Modbus RTU protocol.

The implemented protection functions and their relevant trip thresholds are shown in the following table:

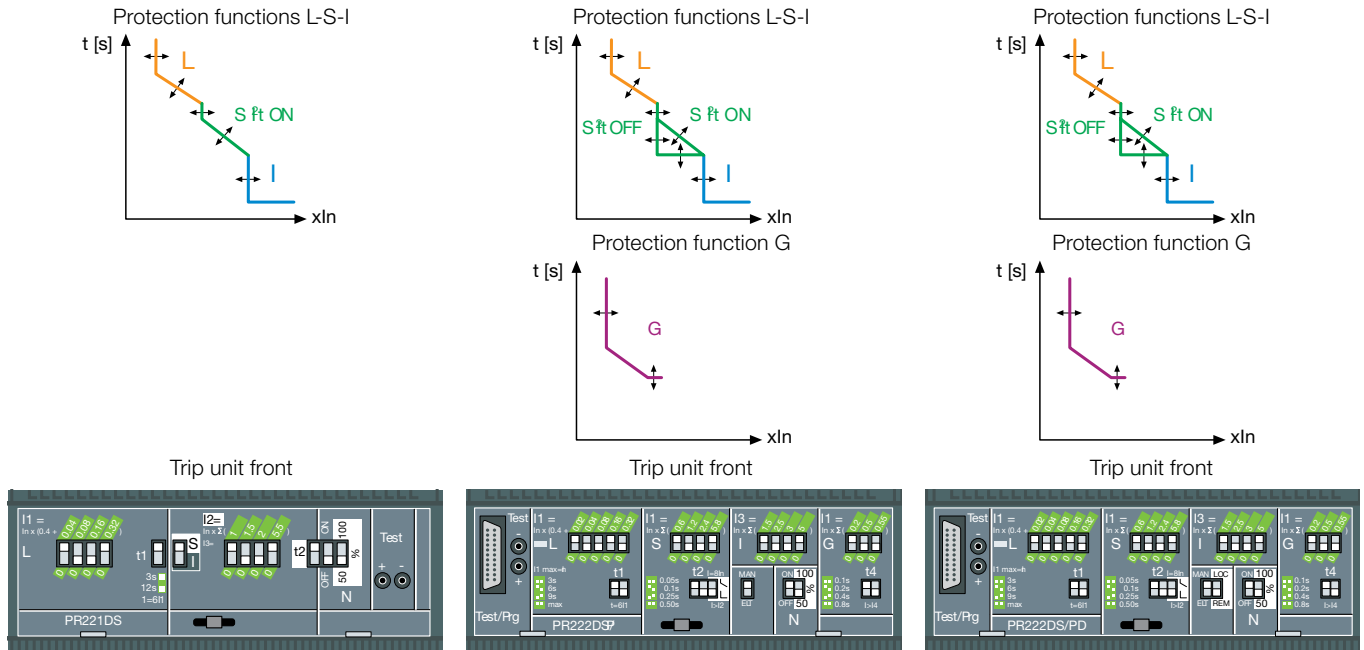

Protection functions and trip threshold settings

- L (cannot be excluded)
 $I_1 = (0.4-1) \times I_n$ curve: $I^2t = K$
- S (can be excluded)
 $I_2 = (1-10) \times I_n$ curve: $I^2t = K$
- I (can be excluded)
 $I_3 = (1-10) \times I_n$

Protection functions and trip threshold settings

- L (cannot be excluded)
 $I_1 = (0.4-1) \times I_n$ curve: $I^2t = K$
- S (can be excluded)
 $I_2 = (0.6-10) \times I_n$ curve: $I^2t = K$ ON
 $I_2 = (0.6-10) \times I_n$ curve: $I^2t = K$ OFF
- I (can be excluded)
 $I_3 = (1.5-12) \times I_n$
- G (can be excluded)
 $I_4 = (0.2-1) \times I_n$ curve: $I^2t = K$

Protection functions and trip threshold settings

- L (cannot be excluded)
 $I_1 = (0.4-1) \times I_n$ curve: $I^2t = K$
- S (can be excluded)
 $I_2 = (0.6-10) \times I_n$ curve: $I^2t = K$ ON
 $I_2 = (0.6-10) \times I_n$ curve: $I^2t = K$ OFF
- I (can be excluded)
 $I_3 = (1.5-12) \times I_n$
- G (can be excluded)
 $I_4 = (0.2-1) \times I_n$ curve: $I^2t = K$

For Tmax T2, T4, T5 and T6 also the electronic trip unit PR221DS-I is available; Complying with the Standard UL 508 "Industrial Control Equipment", these units can be used in a "Combination Motor Controller Type D" (Instantaneous-Trip Circuit Breaker + Magnetic Motor Controller + Overload Relay).

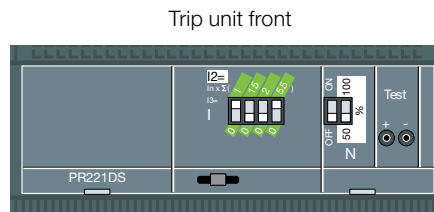
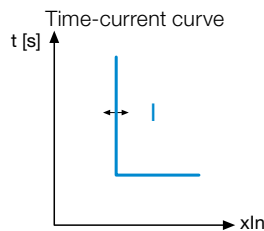

Protection function I

$$I_3 = (1-10) \times I_n$$

4.2.5.1 Setting Examples of a Trip Unit PR222DS/P

Taking into consideration a circuit breaker Tmax T4H250 In 150 equipped with an electronic trip unit PR222DS/P-LSIG

- the letter H identifies the interrupting rating of the circuit breaker which in the example is 65kA at 480V;
 - 250A is the frame size of the circuit breaker;
 - In is the rated current of the circuit breaker which in this specific case is 150A.
- As an example, let's consider some typical settings for the protections L and I.

- setting of protection L

To set the threshold I_1 , once the current I_b required by the load and the I_n of the trip unit are known:

$$\text{Setting}_L = \frac{I_b}{I_n}$$

The available setting immediately higher than or equal to the value obtained is used.

For example, a load requires a current I_b of 69A, given a current I_n equal to 150A:

$$\text{Setting}_L = \frac{69}{150} = 0.46$$

To set this, the dip switches shall be moved to the position corresponding to 0.02 and 0.04 so that $I_1 = I_n \times (0.4^* + 0.02 + 0.04) = 150 \times 0.46 = 69A$.

To select, for example, the curve at 3s, the two dip switches corresponding to t_1 shall be moved to the lowest position.

Figure 10: Dip switch of function L

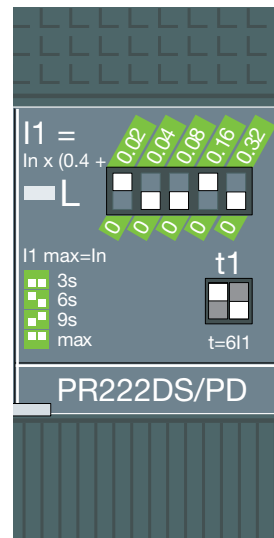

* With function L, the value 0.4 is set by default and must be added to the other coefficients to obtain the correct value of I_1 .

- setting of protection I

To set the threshold I_3 , once the minimum short-circuit current of the circuit $I_{K \min}$ and the current I_n of the trip unit are known:

$$\text{Setting}_I = \frac{I_{K \min}}{I_n}$$

The available setting immediately lower than or equal to the value obtained shall be taken to comply with the condition $I_3 \leq I_{K \min}$.

By assuming in the application a minimum short circuit current $I_{K \min} = 1500\text{A}$, then the following is true:

$$\text{Setting}_I = \frac{1500}{150} = 10$$

The following values can be adjusted:

$$I_3 = 9.5 \times 150 = 1425\text{A.}$$

To obtain $I_3 = 1425\text{A}$, the dip switches shall be moved to correspond to 1.5, 3 and 5 so that:

$$I_3 = I_n \times (1.5+3+5) = 150 \times 9.5 = 1425\text{A.}$$

Figure 11: Dip switch of function I

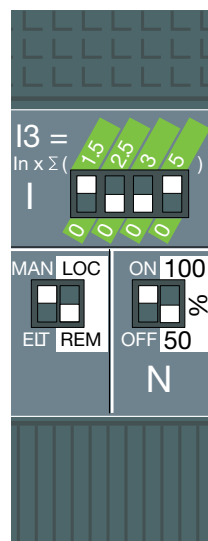

NOTE: For more detailed information on thermal magnetic and electronic trip units for Tmax CBs, reference shall be made to the technical catalogue "ABB Molded Case Circuit Breakers UL 489 and CSA C22.2 Standard".

4.2.6 Electronic Trip Units for Emax Circuit Breakers

For the circuit breakers of Emax series, ABB offers three different types of electronic trip units (PR121/P, PR122/P, PR123/P). The protection functions and their relevant trip thresholds are shown in the following table:

PR121/P LSIG

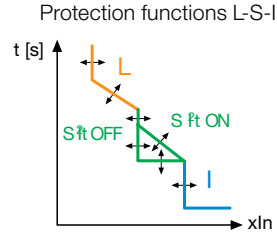

PR122/P LSIG

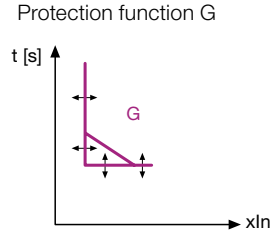

PR123/P LSIG

Trip unit front

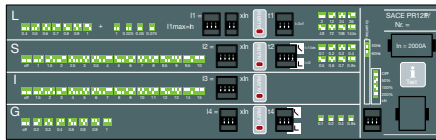

Trip unit front



Trip unit front



Protection functions and trip threshold settings

- L (cannot be excluded)
 $I_1 = (0.4-1) \times I_n$ curve: $t = K/I^2$
- S (can be excluded)
 $I_2 = (1-10) \times I_n$ curve: $t = K/I^2$
 $I_2 = (1-10) \times I_n$ curve: $t = K$
- I (can be excluded)
 $I_3 = (1.5-15) \times I_n$
- G (can be excluded)
 $I_4 = (0.2-1) \times I_n$ curve: $t = K/I^2$
 $I_4 = (0.2-1) \times I_n$ curve: $t = K$

Protection functions and trip threshold settings

- L (cannot be excluded)
 $I_1 = (0.4-1) \times I_n$ curve: $t = K/I^2$
- S (can be excluded)
 $I_2 = (0.6-10) \times I_n$ curve: $t = K/I^2$
 $I_2 = (0.6-10) \times I_n$ curve: $t = K$
- I (can be excluded)
 $I_3 = (1.5-15) \times I_n$
- G (can be excluded)
 $I_4 = (0.2-1) \times I_n$ curve: $t = K/I^2$
 $I_4 = (0.2-1) \times I_n$ curve: $t = K$

Protection functions and trip threshold settings

- L (cannot be excluded)
 $I_1 = (0.4-1) \times I_n$ curve: $t = K/I^2$
- S (can be excluded)
 $I_2 = (0.6-10) \times I_n$ curve: $t = K/I^2$
 $I_2 = (0.6-10) \times I_n$ curve: $t = K$
- I (can be excluded)
 $I_3 = (1.5-15) \times I_n$
- G (can be excluded)
 $I_4 = (0.2-1) \times I_n$ curve: $t = K/I^2$
 $I_4 = (0.2-1) \times I_n$ curve: $t = K$

NOTE: For more detailed information on electronic trip units for Emax CBs, reference shall be made to the technical catalogue "Emax Low Voltage Power Circuit Breakers", marked UL.

5. Trip Curves of ABB Trip Units

The following chapter illustrates the trip curves of ABB thermal magnetic and electronic trip units and gives some examples.

5.1 Trip Curves of Thermal magnetic Trip Units

Let's consider a Tmax T4H250 In 250 equipped with a Thermal magnetic trip unit TMA 250-2500.

Compatible with the rated currents of the loads protected by the circuit breaker, the short circuit currents calculated at its installation point and with the installation requirements, the settings of the protection functions are the following:

I_1 : 200A (overload protection)

I_3 : 2000A (short circuit protection)

Figure 12: Trip curve* of Tmax T4H250 In 250

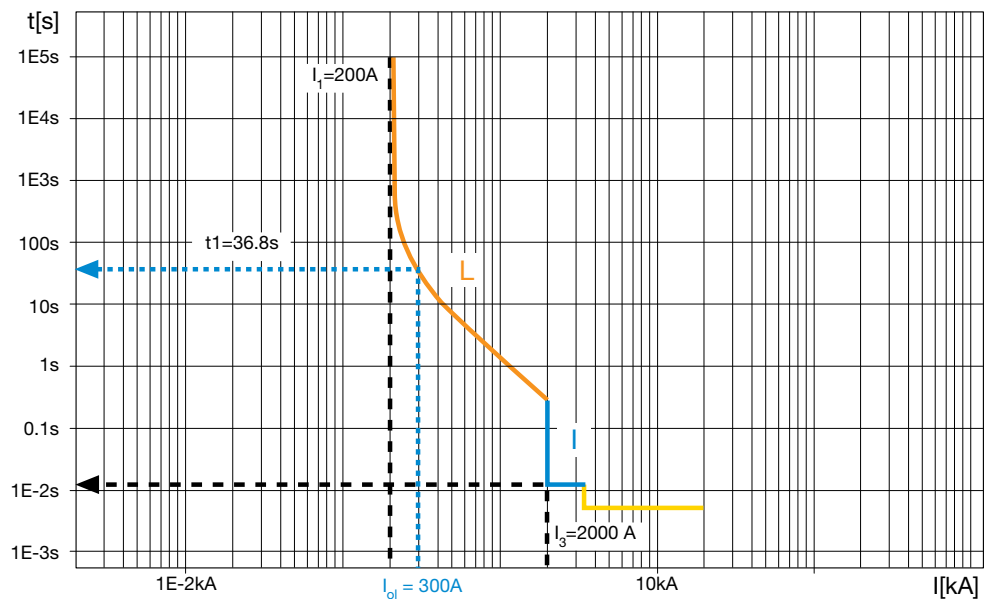

Assuming an overload current I_{oi} of 300A, the trip time of the circuit breaker can be read from the time-current curve as follows:

- 1) start from a current value $I_{oi} = 300A$ on the x-axis
- 2) move vertically to the intersection with the time-current curve
- 3) from the intersection point move horizontally to the left to the intersection with the time-axis
- 4) the value read is the time t_1 , which represents the extinction time of the overload; in this example it is: $t_1 = 36.8s$.

With fault currents exceeding 2000A(which is the set threshold I_3), the circuit breaker shall open almost instantaneously (in tens of milliseconds).

The yellow line represents the instantaneous override of the circuit breaker.

(*) The time-current curve has been traced without considering the tolerances and under "hot trip conditions".

5.2 Trip Curves of Electronic Trip Units

5.2.1 Functions L and S

Curves $t=K/I^2$ (I^2t ON) of Functions L and S

A circuit breaker Tmax T4H250 equipped with an electronic trip unit PR222DS/P-LSIG In 250 is considered; protection functions L and S are activated while protection I is not activated.

The curve $I^2t = K$ of function S has been positioned to ON, whereas for function L such curve is set by default (see Chapter 4, clause 4.2.1 “Overload Protection (L)”); the trip curve of the circuit breaker is represented in Figure 13 (the yellow line is associated to the instantaneous override of the circuit breaker).

Figure 13: Time-current curve of Tmax T4H250 PR222DS/P-LSIG In 250 (I^2t ON)

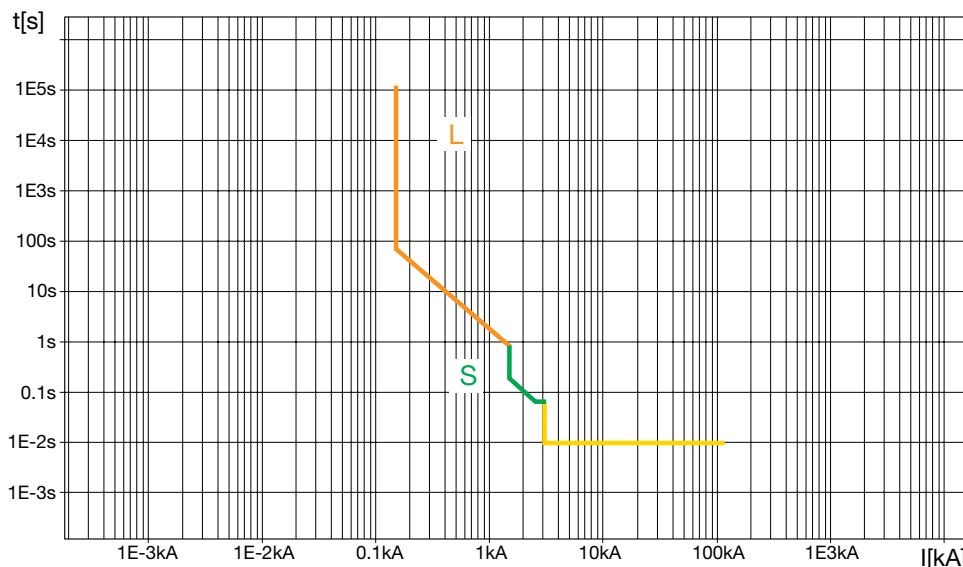

Describing in details function L and considering the following settings:

$$I_1 = 0.5 \times I_n = 0.5 \times 250 = 125A \text{ (long time pickup)}$$

$$t_1 = 3s \text{ (long time delay)}$$

Here are some indications on how to read and what information to get from the reading of the inverse time curve with constant let-through energy characteristics (from a conceptual point of view this is valid also for function S with curve $I^2t = K$).

Assuming a fault current $I_{oi} = 375A$, the clearing time of the fault can be read directly from the curve represented in Figure 14, as follows:

- 1) start from the fault current value I_{oi} on the horizontal axis
- 2) move vertically to the intersection with the time-current curve
- 3) from the intersection point move horizontally to the left to cross the time-axis
- 4) the value read is the time t_1 , which represents the extinction time of the overload; in this example it is equal to 12s

Figure 14: Curve - 3s - of Function L

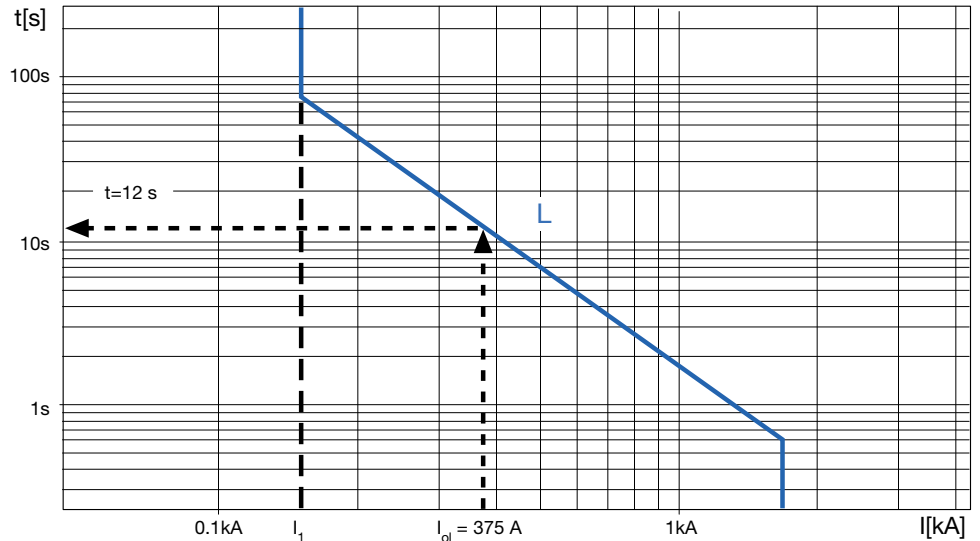

The time read directly on the graph can also be obtained analytically as follows. Since the curve under examination has I^2t constant, the condition below shall be always true:

$$(6 \times I_1)^2 \times t_1 = \text{const} = I^2 \times t \quad (*)$$

(*) This relationship is valid for overload currents up to $12 \times I_n$.

Where:

- the expression $(6 \times I_1)^2 \times t_1$ is the specific let-through energy associated to the curve at 3s;
- the expression $I^2 \times t$ represents the product between a generic overload current squared and the time necessary to the protection to open the circuit.

The trip time of the protection function for a fault current $I_{oi} = 375\text{A}$ can be obtained as follows:

$$- (6 \times I_1)^2 \times t_1 = I_{oi}^2 \times t \quad \longrightarrow \quad t = \frac{(6 \times 125)^2 \times 3}{375^2} = 12\text{s} \quad \longrightarrow \quad t = 12\text{s}$$

If, for example, the installation requires that the assumed overload of 375A is cut off in a time t_e lower than 15s, the characteristic trip curve at 3s fully meets the requirement, because it ensures that the protection trips within 12s.

This conclusion can be reached:

from the relationship $(6 \times I_1)^2 \times t_1 = I^2 \times t = \text{const}$;

for a fault clearing time $t_e \leq 15\text{s}$

it results: $(6 \times I_1)^2 \times t = 375^2 \times t_e$

from which: $(6 \times 125)^2 \times t = 375^2 \times 15$

to obtain the time t (maximum trip time delay to comply with the installation requirements)

$$t = \frac{375^2 \times 15}{(6 \times 125)^2} = 3,75\text{s}$$

The suitable curve is that with " t_1 " lower than " t "; therefore the curve to use is that at 3s. The reasoning above can be applied to function S with curve at $I^2t = K$ (I^2t ON).

Curves $t = K (I^2t \text{ OFF})$ of function S

Now take into consideration the previous example, but with the curve of protection S set at constant time $t=K (I^2t \text{ OFF})$; in this case the time-current curve is as follows:

Figure 15: Time-current curve of Tmax T4H250 PR222DS/P-LSIG In 250 ($I^2t = K \text{ OFF}$)

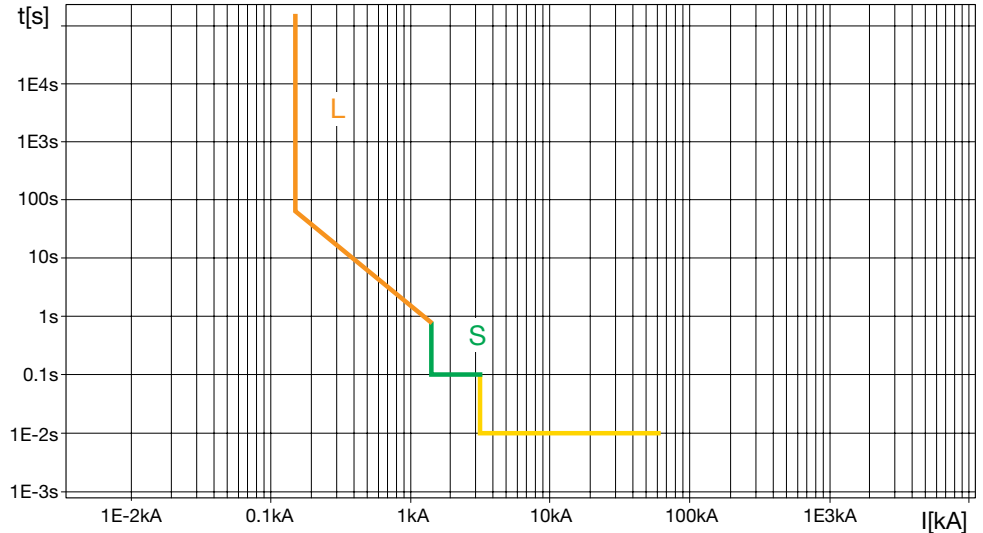

By setting a generic value for function S:

$$I_2 = 5.80 \times I_n = 5.80 \times 250 = 1450\text{A (short time pickup)}$$

$$t_2 = 0.10\text{s (short time delay)}$$

If a short circuit occurs, all the overcurrents I_g higher than or equal to I_2 shall be cut off within the time t_2 , as it can be read from the graph of Figure 16 as follows:

- 1) start on the x-axis from a fault current value I_g (in Figure 16 $I_g = 2000\text{A}$)
- 2) move vertically to the intersection with the time-current curve
- 3) from the intersection point move horizontally to the left to cross the time-axis
- 4) the value read is the time t_2 , which represents the maximum fault extinction time; in this case, it's 100ms.

Figure 16: Function S at $t = 0.1\text{s}$

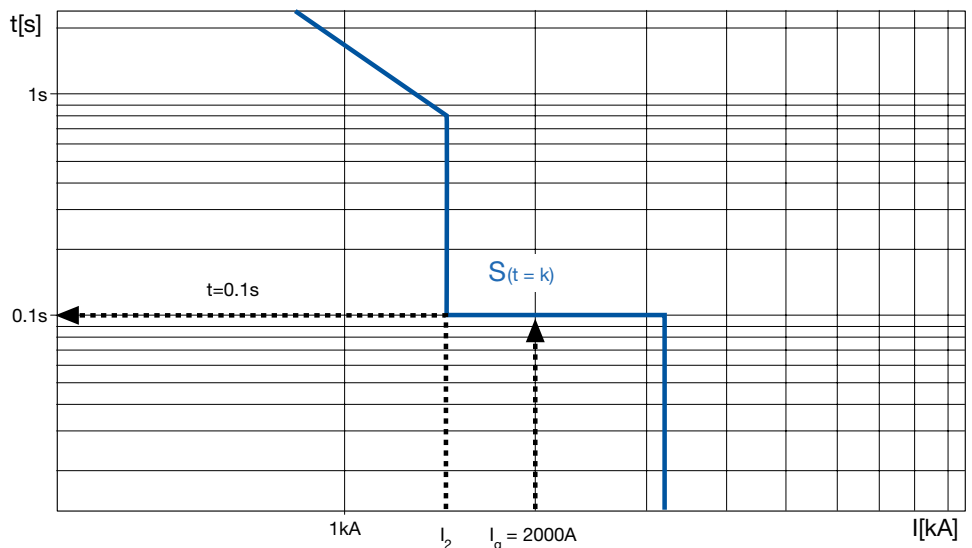

Trip curves of ABB Trip units

5.2.2 Function I

By considering again a circuit breaker Tmax T4H250 equipped with a trip unit PR222DS/P-LSIG In 250 and setting as an example the following values:

- Function L (long time-delay trip function):
 $I_1 = 1 \times I_n = 1 \times 250 = 250\text{A}$ (long time pickup)
Curve: 3s (long time delay)
- Function S (short time-delay trip function):
OFF
- Function I (instantaneous trip function):
 $I_3 = 7 \times I_n = 7 \times 250 = 1.75\text{kA}$ (instantaneous pickup setting)

The characteristic trip curve obtained is represented in Figure 17.

Figure 17: Tmax T4H250 PR222DS/P-LSIG In 250

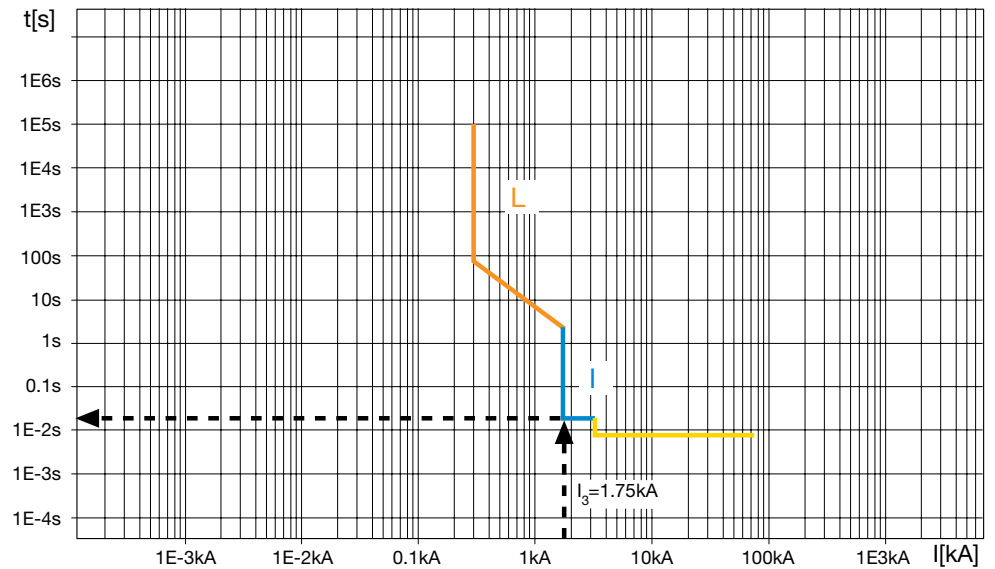

All the short-circuit currents exceeding 1.75kA shall be cut off in a few milliseconds. The yellow line represents the instantaneous override of the circuit breaker.

5.2.3 Function G

Function G for ground-fault protection is available.

Here are two examples of the curves associated with this protective function, first the trip curve with $I^2t = K$ and then the trip curve with $t = K$ are examined.

A circuit breaker Emax E1B 1600 equipped with a trip unit PR122P-LSIG $I_n = 1600A$ is used.

Curves $I^2t = K$

The settings of function G are:

Characteristic $I^2t = K$: ON

Threshold: $I_4 = 0.20 \times 1600 = 0.32kA$ (ground-fault pickup setting)

Curve: $t_4 = 0.10s$ (ground fault-delay)

The characteristic curve obtained is represented in Figure 18.

Figure 18: Function G at $t = K/I^2$

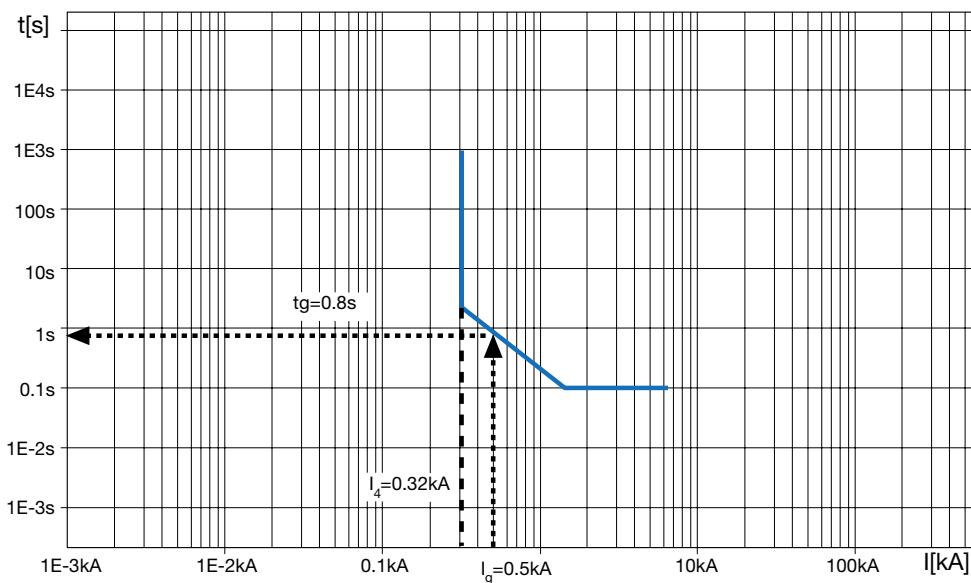

With a prospective fault current $I_g = 0.5kA$ on the x-axis, move vertically to the intersection with the curve; from this intersection point move to the left to cut the time-axis. The value read is the fault clearing time t_g ; in this example $t_g = 0.8s$.

Curves $t = K$

The settings of function G are:

Characteristic $I^2t = K$: OFF

Threshold: $I_4 = 0.20 \times 1600 = 0.32\text{kA}$ (ground-fault pickup setting)

Curve: $t_4 = 0.10\text{s}$ (ground-fault delay)

The characteristic trip curve obtained is represented in Figure 19.

Figure 19: Function G at $t = K$

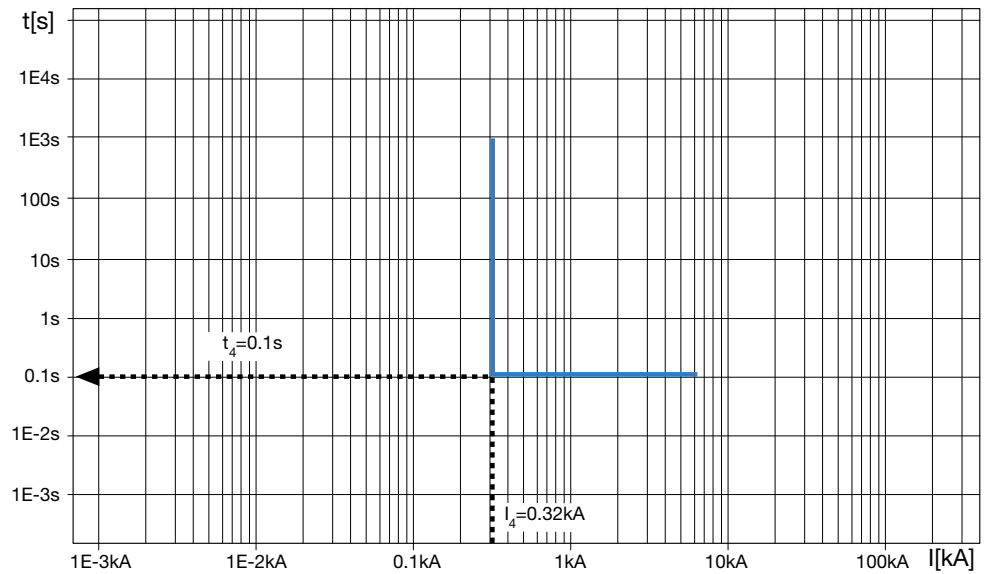

As it results from the reading of the graph, the ground fault currents exceeding the set threshold $I_4 = 0.32\text{kA}$ shall be quenched in a time t_4 equal to 0.1s .

NOTES:

- 1) As regards the protection functions just described, for more detailed information on the possible settings of the thresholds and the trip times and on the possible curves available with electronic trip units on Tmax and Emax CBs, reference is to be made to the relevant technical catalogues by ABB.
- 2) The time-current curves used in the examples of this chapter have been plotted without considering the tolerance over trip thresholds and times. For a thorough analysis please refer to Annex A.

6. Curves of Current Limiting Circuit Breakers: Let-Through Values of I^2t and Peak Current

For the molded-case circuit breakers marked “Current Limiting”, the peak current and the energy let-through curves have been made available.

These curves are shown in Figures 20 and 21 and once the available short-circuit current is known, allow one to determine:

- the maximum peak let-through current (from the limitation curves)
- the let-through I^2t value (from the specific let-through energy curves).

Figure 20: Specific let-through energy curve

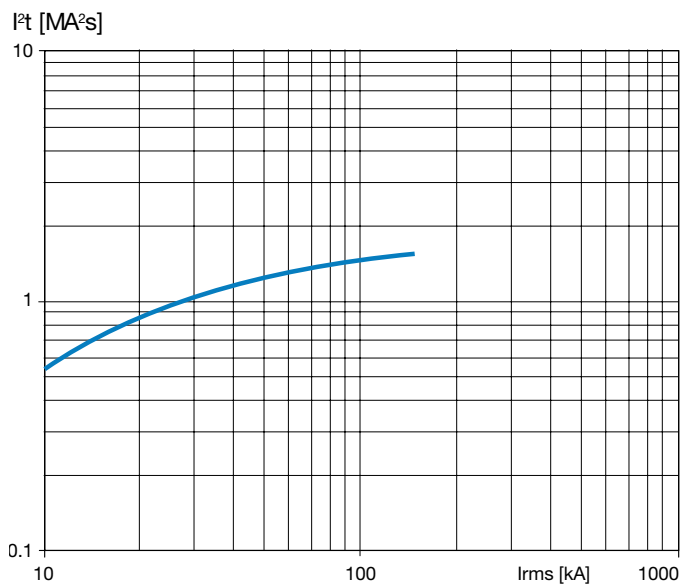
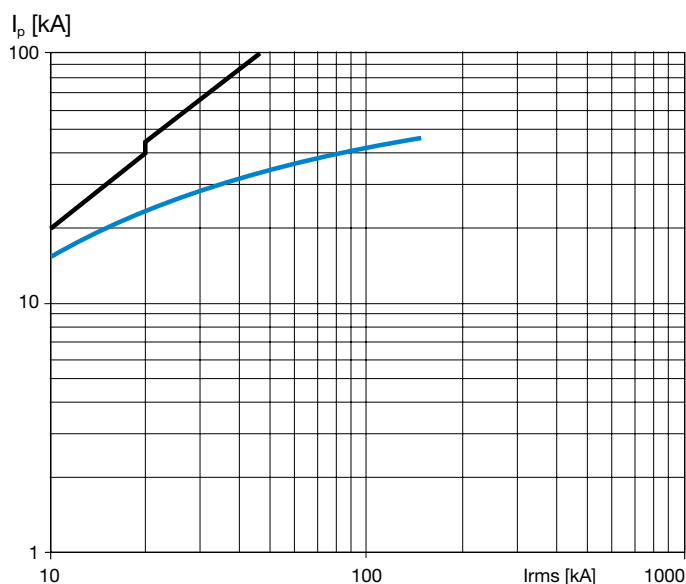

Figure 21: Limitation curve



The limitation curves are associated with the voltage applied to the circuit breaker; in general, for the same available short circuit current, if the voltage applied is higher, the limiting capacity of the device shall decrease, letting through a higher peak current and I^2t .

These curves are made available for each rated voltage of the device. Their use is prescribed in the Standard UL 508A “Industrial Control Panels” and in particular in the supplement SB: SHORT CIRCUIT CURRENT RATINGS FOR INDUSTRIAL CONTROL PANELS.

Curves of current limiting circuit breakers

From the limitation curves the peak value let-through and/or the I^2t value can be determined as follows:

- 1) choose the curves corresponding to the proper rated voltage.
- 2) select the available short circuit current along the horizontal axis.
- 3) move vertically to the intersection with the curve corresponding to the rated current of the trip unit.
- 4) move horizontally left to the intersection with the vertical axis to determine the peak let-through current or I^2t value.

Consider a Tmax T4H250 equipped with a trip unit PR222DS/P-LSIG In 250; by assuming an available short-circuit current of 20kA at the installation point, we obtain the peak current and the let-through energy by reading them on their relevant curves.

Specific let-through energy curve

With a rated voltage of 480V in the circuit, the following curve is available:

Figure 22: Specific let-through energy curves @ 480V

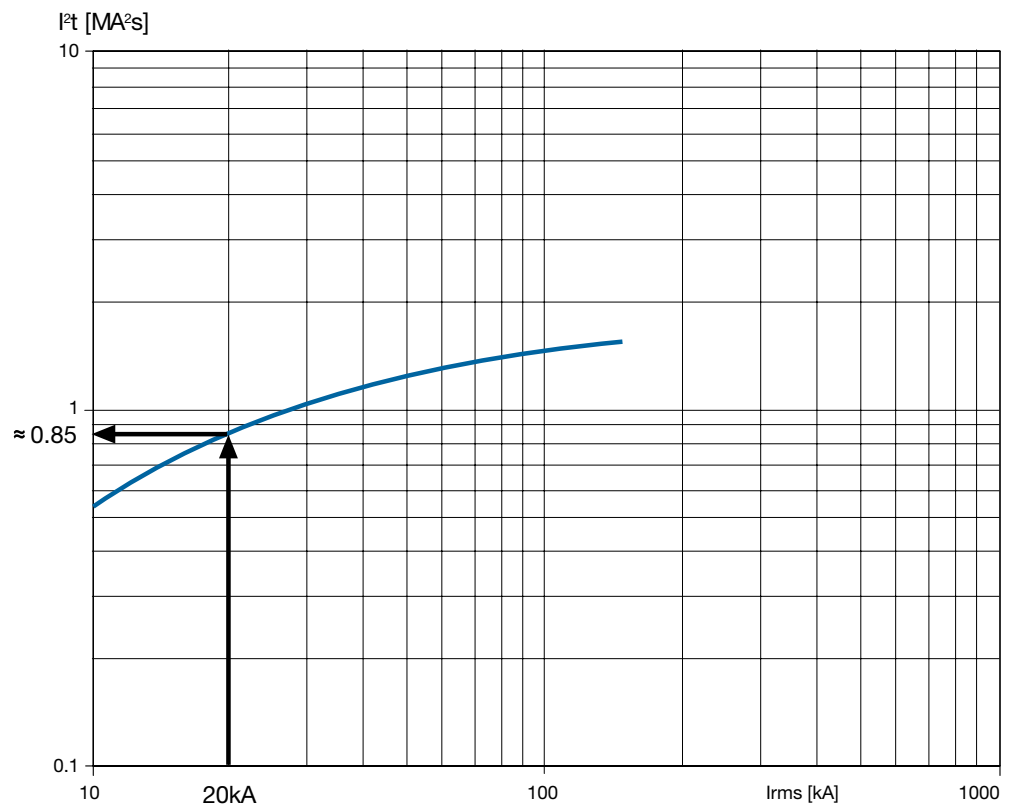

As it can be read in the graph, corresponding to an available short-circuit current of 20kA, the energy let-through by the circuit breaker is about 0.85 MA^2s .

Curves of current limiting circuit breakers

Limitation curve

With a rated voltage of 480V in the circuit, the following curve is available:

Figure 23: Limitation curve of T4 250 at 480V

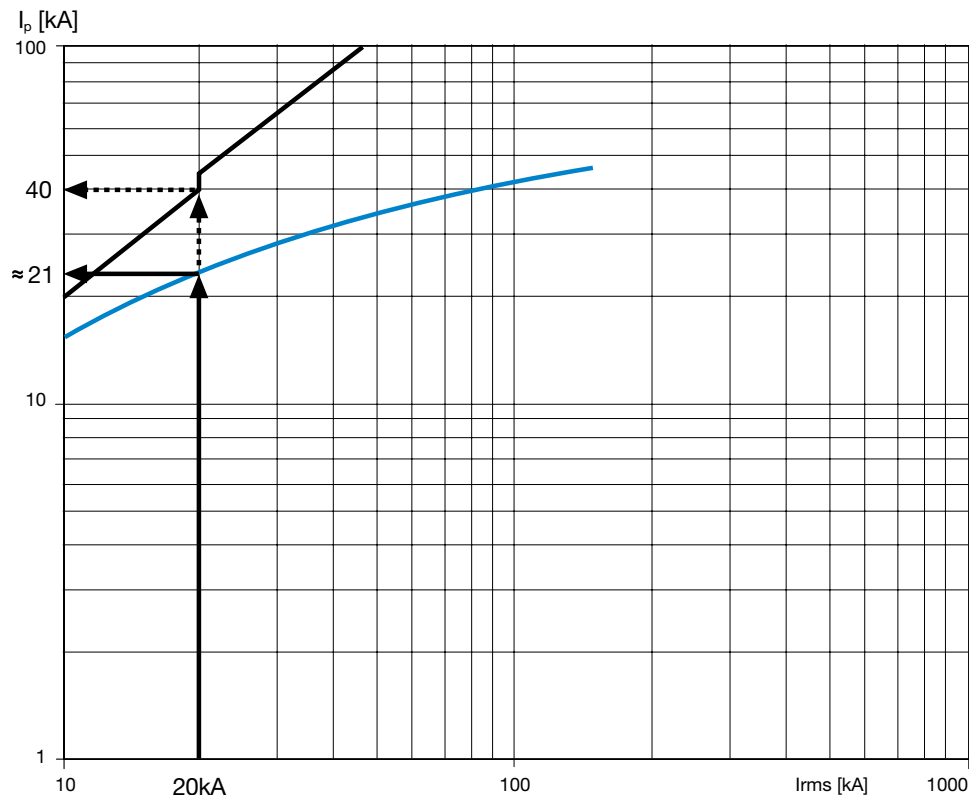

For an available short circuit current of 20kA, the peak value let-through by the circuit breaker is about 21kA.

As it can be noted, with 20kA of available short circuit current, without the limiting action of the circuit breaker, there would have been a peak let-through current of 40kA.

It is important to make clear that the limiting effect of a circuit breaker does not influence its choice from the point of view of its interrupting rating since the adequate interrupting rating of a circuit breaker is chosen according to the prospective short-circuit current calculated at its installation point and according to the voltage of the system, without considering the limitation of the current peak introduced by the circuit breaker itself. The equipment and the components which take advantage of the limiting effect of the circuit breaker are on the load side.

Annex A: Tolerance in the Trip Curves

The time-current curves used in the examples of Chapter 5 have been traced without taking into consideration the tolerance over the currents and the trip times.

The tolerance is the range within which a protection function can operate. All the electronic trip units have, for each protection function, a well defined tolerance.

As a consequence, their tripping is represented by two curves: the first curve reports the highest trip times (upper curve) while the other one reports the fastest trip times (lower curve).

Consider a circuit breaker Tmax T4H250 equipped with a trip unit PR222DS/P-LSIG In 250 and fixing these settings:

- Function L (long time delay trip function):
 $I_1 = 1 \times I_n = 1 \times 250 = 250\text{A}$ (long time pickup)
 curve: 3s (long time delay)
- Function S (short time-delay trip function) $t = K$:
 $I_2 = 5.80 \times I_n = 5.80 \times 250 = 1450\text{A}$
 $t_2 = 0.50\text{s}$
- Function I (instantaneous trip function):
 OFF

protective function S can be analyzed as follows:

The green curve represents the real characteristic trip curve of the trip unit, including tolerances ($I_2 \pm 10\%$ and $t_2 \pm 10\%$); the red curve represents instead the trip curve traced without keeping into account the tolerance values.

With the set values it shows:

- for fault currents ranging from $I_2 - 10\%$ and $I_2 + 10\%$ (tolerance over the trip threshold), protection S shall trip with a delay time t_2 from 0.45 to 4.75s;
- for faults currents exceeding $I_2 + 10\%$, protection S shall trip with a delay time t_2 from 0.45 to 0.55s (tolerance over the trip times).

This can be observed also by reading the curve in Figure 24.

Figure 24: Tolerances of function S at $t = K$

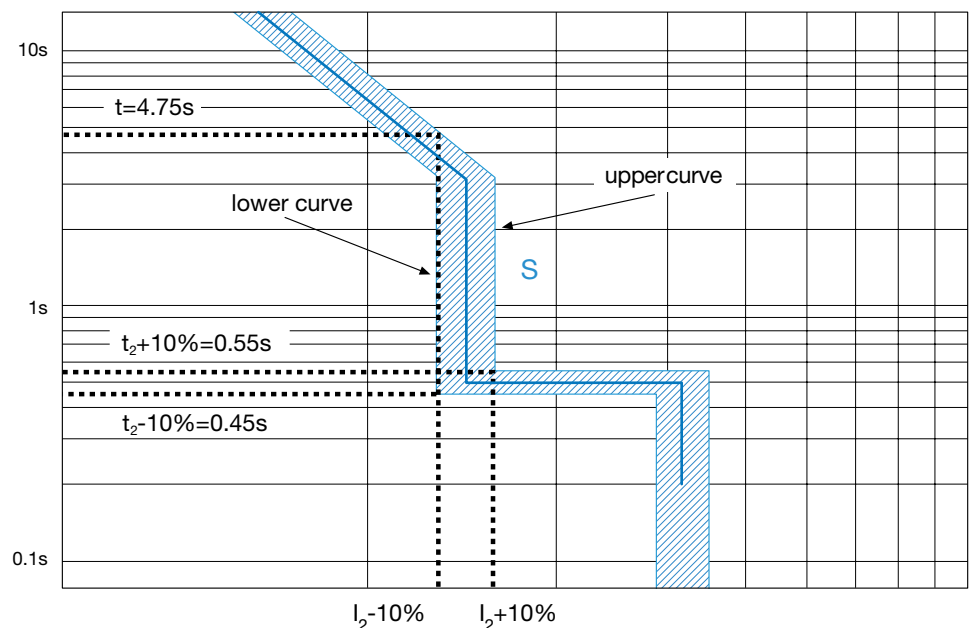

| | |
|------------|---|
| TMF | Thermal magnetic trip unit with fixed thermal and magnetic thresholds |
| TMD | Thermal magnetic trip unit with adjustable thermal threshold and fixed magnetic threshold |
| TMA | Thermal magnetic trip unit with adjustable thermal and magnetic thresholds |
| MA | magnetic only trip unit with adjustable threshold |
| Function L | overload protection (long time-delay trip function) |
| Function S | short-circuit protection with delayed trip (short time delay trip function) |
| Function I | instantaneous short-circuit protection (instantaneous trip function) |
| Function G | ground-fault protection (ground-fault trip function) |
| I_n | rated current of the circuit breaker |
| I_1 | long time pickup |
| t_1 | long time delay |
| I_2 | short time pickup |
| t_2 | short time delay |
| I_3 | instantaneous pickup setting |
| I_4 | ground-fault pickup setting |
| t_4 | ground-fault delay |
| I_{rms} | available short-circuit current |
| I_p | peak current |
| I^2t | specific let-through energy |
| CBs | Circuit Breakers |
| K | Constant |

Contact us

ABB Inc.

Low Voltage Control Products & Systems

1206 Hatton Road

Wichita Falls, TX 76302

Phone: 888-385-1221

940-397-7000

Fax: 940-397-7085

USA Technical help:

888-385-1221, Option 4

7:30AM to 5:30PM, CST,

Monday - Friday

Find USA Authorized Distributors

www.abb.us/lowvoltage

LV153 [1SXU210170B0201] June, 2009

Power and productivity
for a better world™

